

Through-penetration Firestop Systems

System No. W-L-7274

ANSI/UL1479 (ASTM E814)	CAN / ULC S115
F Rating – 2 Hr	F Rating – 2 Hr
T Rating – 1/2 Hr	FT Rating – 1/2 Hr
	FH Rating – 2 Hr
	FTH Rating – 1/2 Hr

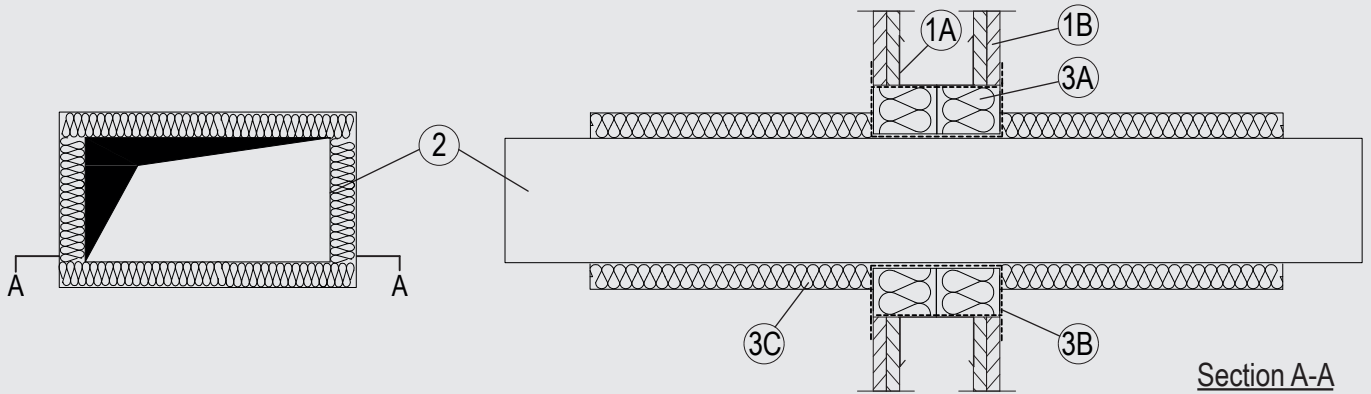

1. Wall Assembly

The 1 or 2 hr fire rated gypsum board/stud wall assembly shall be constructed of the materials and in the manner described in the individual U400, V400 or W400 Series Wall and Partition Design in the UL Fire Resistance Directory and shall include the following construction features:

- A. Studs – Steel studs to be min 2-3/4 in. (70 mm) wide spaced max 24 in. (610 mm) OC. Additional studs used to completely frame the opening.
- B. Gypsum Board* – The gypsum board type, thickness, number of layers, fastener type and sheet orientation shall be as specified in the individual Wall and Partition Design in the UL Fire Resistance Directory. Max size of framed opening to be 15-3/4 in. (400 mm) high by 19-5/8 in. (500 mm) wide

2. Duct

Single duct to be installed within the opening. The annular space between the duct and the periphery of the opening to be 2 in (50 mm). Ducts to be rigidly supported on both sides of the wall assembly. The following penetrants may be used:

- A. Max 15-3/4 in. (400 mm) by 11-3/4 in. (300 mm) galvanized steel duct min. 18 AWG (1 mm).

3. Firestop System

The Firestop System shall consist of the following:

- A. Packing Material – Nom. 2-3/8 in. (60 mm) thick mineral wool board min. 9.3 pcf (150 kg/m³) firmly packed into the opening of the wall as a permanent form, flush with both surfaces of wall.
- B. Fill, Void or Cavity Material* – Min. 1/16 in. (2 mm) dry film thickness to be applied, coating the inside surface of the opening before installation of the packing material and over the full surface of the mineral wool boards, and overlapping onto the wall by min. 3/4 in. (20 mm).

Flamro Brandschutz-Systeme GmbH – FLAMMOTECT-A

- C. Duct Insulation – Nom. 1-1/4 in. (30 mm) thick 'Klimarock' mineral fibre lamella mat, min density 2.5 pcf (40 kg/m³), wrapped around duct for min. 10 in. (250 mm) on both faces and secured by min 24 AWG steel wire at 2in. (50 mm) and 8in. (200 mm) from the faces of the firestop.

*Indicates such products shall bear the UL or cUL Certification Mark for jurisdictions employing the UL or cUL Certification (such as Canada), respectively. Reprinted from Product iQ with permission from UL Solutions. ©2024 UL LLC.