

Through-penetration Firestop Systems

System No. W-L-2686

ANSI/UL1479 (ASTM E814)	CAN / ULC S115
F Rating – 2 Hr	F Rating – 2 Hr
T Rating – 2 Hr	FT Rating – 2 Hr
	FH Rating – 2 Hr
	FTH Rating – 2 Hr

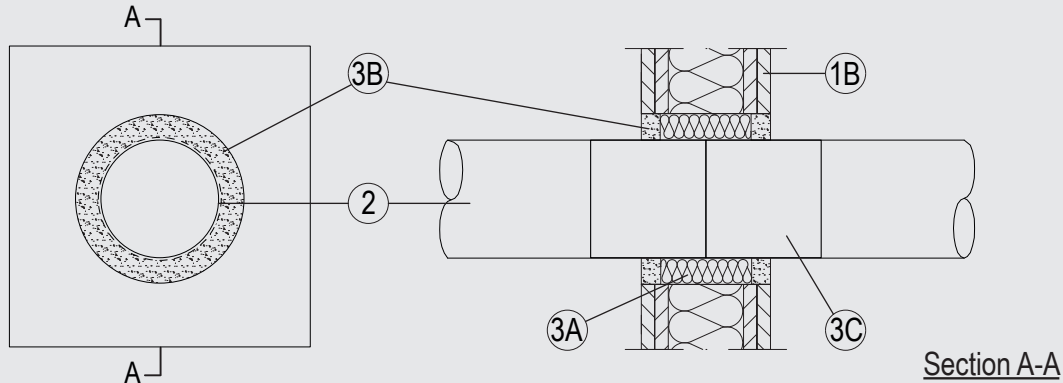

1. Wall Assembly

The 1 or 2 hr fire rated gypsum board/stud wall assembly shall be constructed of the materials and in the manner described in the individual U400, V400 or W400 Series Wall and Partition Design in the UL Fire Resistance Directory and shall include the following construction features:

- A. Studs (not shown in diagram) – Steel studs to be min 2-3/4 in. (70 mm) wide spaced max 24 in. (610 mm) OC.
- B. Gypsum Board* – The gypsum board type, thickness, number of layers, fastener type and sheet orientation shall be as specified in the individual Wall and Partition Design in the UL Fire Resistance Directory. Max size of opening to be 5 in. (125 mm) diameter.

2. Pipes / Tubes

Single to be installed within the opening. The annular space between the pipes and the periphery of the opening to be 1 in (25 mm). Pipes to be rigidly supported on both sides of the wall assembly. The following penetrants may be used:

- A. Nominal 3 in (75mm) diameter, 1/8 in. (3.6 mm) wall thickness PVC pipe for use in closed (process or supply) or vented (drain, waste or vent) piping systems.

3. Firestop System

The Firestop System shall consist of the following:

- A. Packing Material – Min. 9.3 pcf (150 kg/m³) mineral wool firmly packed into the opening of the wall as a permanent form. Packing material to be recessed 1 in. space to both surfaces of wall.
- B. Packing Material – Gypsum mortar minimum 1 in. depth on both sides.
- C. Fill, Void or Cavity Material* – 2 lengths of 2 layers of 1/16 in (1.5 mm) by 4 in. (100 mm) wrap butt jointed centrally within the depth of the seal around the pipe to a total length of 8 in. (200 mm).

Flamro Brandschutz-Systeme GmbH – DG-CR BS

*Indicates such products shall bear the UL or cUL Certification Mark for jurisdictions employing the UL or cUL Certification (such as Canada), respectively. Reprinted from Product iQ with permission from UL Solutions. ©2024 UL LLC.