

# Through-penetration Firestop Systems

## System No. W-J-8086

ANSI/UL1479 (ASTM E814)

CAN / ULC S115

F Rating – 2 Hr	F Rating – 2 Hr
T Rating – 1 1/2 Hr	FT Rating – 1 1/2 Hr
	FH Rating – 2 Hr
	FTH Rating – 1 1/2 Hr

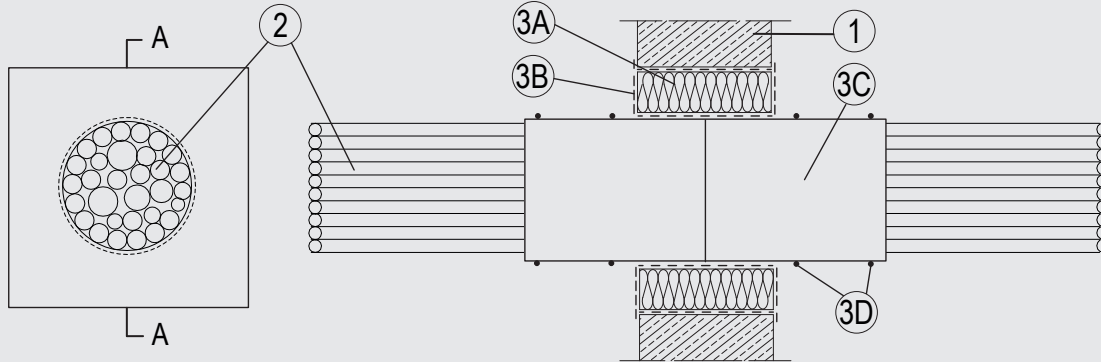

Section A-A

### 1. Wall Assembly

Min. 4-1/2 in. (115 mm) thick lightweight or normal weight (100-150 pcf or 1600 - 2400 kg/m<sup>3</sup>) concrete. Wall may also be constructed of any UL Classified Concrete Blocks\*. Opening shall be rectangular or circular with max dimensions of 2.1 in. (52 mm). See Concrete Blocks (CAZT) in the Fire Resistance Directory for names of manufacturers.

### 2. Services

1-1/4 in. (32 mm) diameter (or smaller) PE-HD conduit in bundles of diameter 4 in. (100 mm) or smaller, containing the following cables:

- A. Max 5/C No. 15 AWG (1.5 mm) diameter (or smaller), copper conductor cable with EPR insulation and Rubber jacket.
- B. Max 5/C No. 15 AWG (1.5 mm) diameter (or smaller), copper conductor cable with XPPE insulation and EVA jacket.
- C. Max 5/C No. 15 AWG (1.5 mm) diameter (or smaller), copper conductor cable with PVC insulation and PVC jacket.
- D. Max 20/C No. 23 AWG (0.6 mm) diameter (or smaller), copper conductor telecommunication cable with PE jacket.
- E. Max 3/C No. 15 AWG (1.5 mm) diameter (or smaller), copper conductor cable with PVC insulation and PVC jacket.

### 3. Firestop System

The Firestop System shall consist of the following:

- A. Packing Material – Nom. 2-3/8 in. (60 mm) thick mineral wool boards min. 3.7 pcf (60 kg/m<sup>3</sup>) firmly packed into the opening of the wall as a permanent form. Packing material to be installed flush with both surfaces of wall.
- B. Fill, Void or Cavity Material\* – Min. 1/16 in. (2 mm) dry film thickness to be applied, coating the inside surface of the opening before installation of the packing material and over the full surface of the mineral wool boards, and overlapping onto the wall by min. 3/4 in. (20 mm) on both sides of wall.

**Flamro Brandschutz-Systeme GmbH – FLAMMOTECT-A**

- C. Fill, Void or Cavity Material\* – 2 lengths of 3 layers of 1/16 in. (1.5 mm) by 5 in. (125 mm) wrap butt jointed centrally within the depth of the seal around the conduit to a total length of 10 in. (250 mm).

**Flamro Brandschutz-Systeme GmbH – DG-CR 1.5**

- D. 24 AWG Steel wire tied around 3C at nominally 1 in. (25 mm) and 2 in. (51 mm) from both faces of the seal.

\*Indicates such products shall bear the UL or cUL Certification Mark for jurisdictions employing the UL or cUL Certification (such as Canada), respectively. Reprinted from Product iQ with permission from UL Solutions. ©2024 UL LLC.