

Through-penetration Firestop Systems

System No. W-J-4080

ANSI/UL1479 (ASTM E814)

CAN / ULC S115

F Rating – 3 Hr	F Rating – 3 Hr
T Rating – 2 Hr	FT Rating – 2 Hr
	FH Rating – 3 Hr
	FTH Rating – 2 Hr

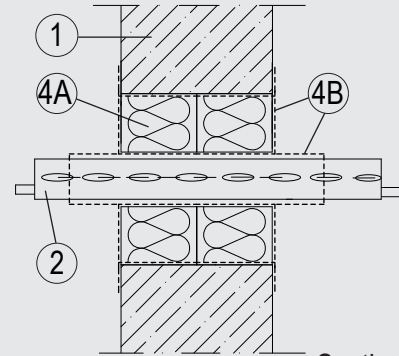
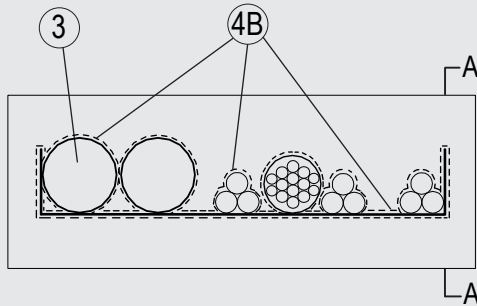

Section A-A

1. Wall and Floor Assembly

Min 4-1/2 in. (115 mm) thick lightweight or normal weight (100-150 pcf or 1600-2400 kg/m³) concrete. Wall may also be constructed of any UL Classified Concrete Blocks*. Opening shall be rectangular with max dimensions of 23-1/2 in. (600 mm) by 4-1/3 in. (110 mm).

See Concrete Blocks (CAZT) category in Fire Resistance Directory for names of manufacturers.

2. Cable Tray*

Max 20 in. (500 mm) wide by max 2-3/8 in. (60 mm) deep open-perforated or solid sheet cable tray with side rails formed of min 0.05 in. (1.5 mm) thick steel. Cable trays to be rigidly supported on both sides of the wall assembly.

3. Cables

Aggregate cross-sectional area of cables in cable tray not to exceed 33.73 percent of the cross-sectional area of the cable tray based on a max 2-5/8 in. (68 mm) cable loading depth within the tray. Cable bundles of different types shall be separated by min. 1 in. (25 mm). Any combination of the following types and sizes of cables may be used:

- A. Max 3/C 185 mm diam (or smaller), copper conductor cable with PVC insulation and jacket.
- B. Max 5/C No. 15 AWG (1.5 mm) diam (or smaller), copper conductor cable with EPR insulation and Rubber jacket.
- C. Max 5/C No. 15 AWG (1.5 mm) diam (or smaller), copper conductor cable with XPLE insulation and EVA jacket.
- D. Max 20/C No. 19 AWG (0.6 mm) diam (or smaller), copper conductor telecommunication cables PE jacket.
- E. Max 5/C No. 15 AWG (1.5 mm) diam (or smaller), copper conductor cable with PVC insulation and PVC jacket.

4. Firestop System

The Firestop System shall consist of the following:

- A. Packing material – Nom. 2-3/8 in. (60 mm) thick mineral wool boards min. 9.3 pcf (150 kg/m³) firmly packed into the opening of the wall as a permanent form. Packing material to be installed flush with both surfaces of wall.
- B. Fill, Void or Cavity Material* – Min. 1/16 in. (2 mm) dry film thickness to be applied inside the aperture before installation and over the full surface of the mineral wool boards, and overlapping onto the wall by min. 3/4 in. (20 mm). Min. 1/32 in. (1 mm) dry film thickness to be applied over the surface of the cables and tray to a minimum length of 7-7/8 in. (200 mm) from both faces of the board.

Flamro Brandschutz-Systeme GmbH – FLAMMOTECT-A

*Indicates such products shall bear the UL or cUL Certification Mark for jurisdictions employing the UL or cUL Certification (such as Canada), respectively. Reprinted from Product iQ with permission from UL Solutions. ©2024 UL LLC.