

System Flammotect 4 × 60 mm

Ablative mineral fibre board seal

Sealing system made of mineral fibre boards and an ablative coating for electrical installations of all types as well as non-combustible pipes.

Fire resistance class max. EI 240 in accordance with EN 13501-2 as per ETA-22/0052.

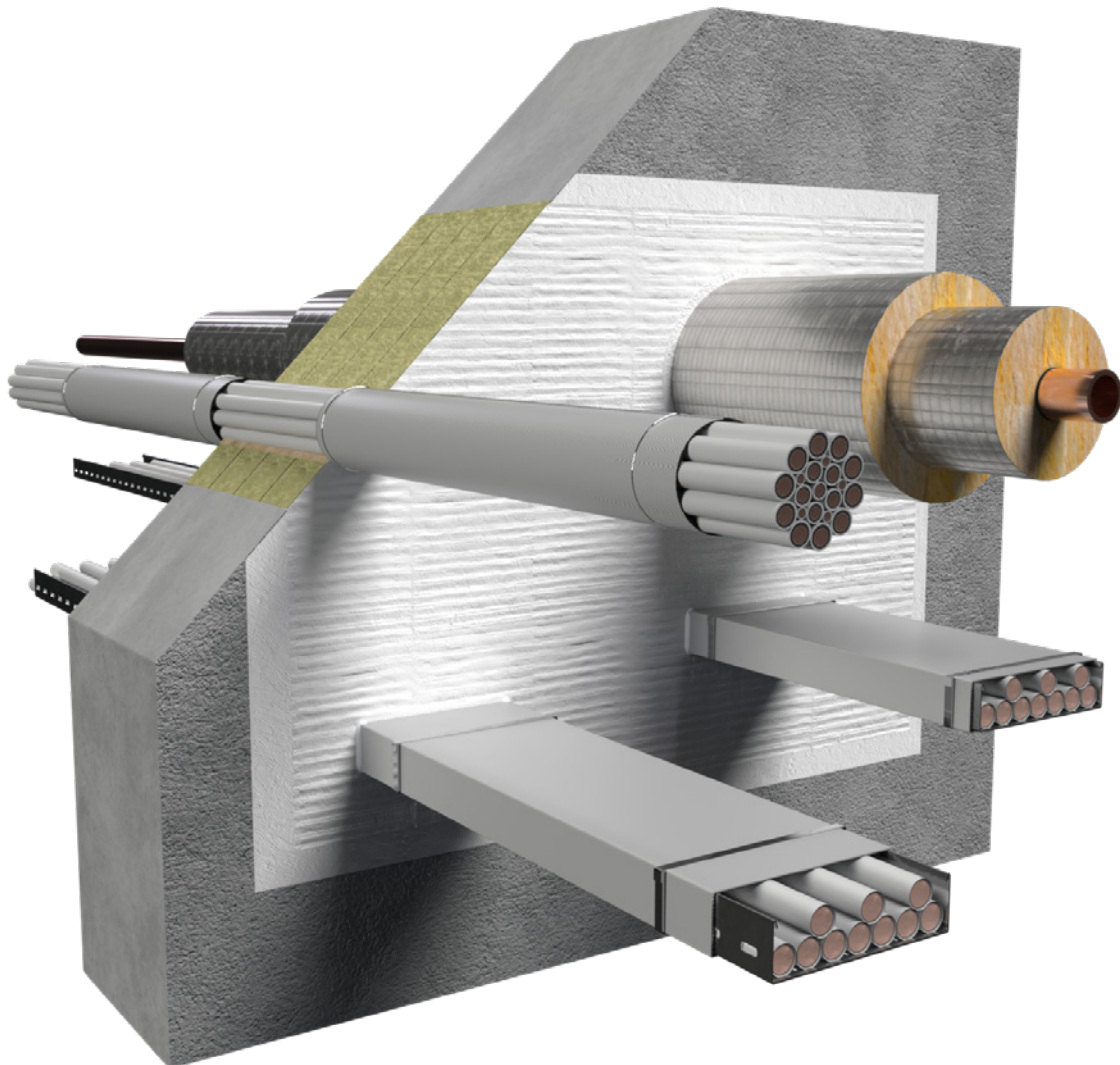

System Flammotect 4 × 60 mm

Table of contents

	Page
1. Preliminary remarks / overview	3
1.1 Use of the instructions.....	3
1.2 Safety instructions.....	3
1.3 Building elements.....	4
2. Allowed services	4
2.1 Cables.....	4
2.2 Non-combustible pipes.....	4
3. Thicknesses, sizes and spacing.....	5
3.1 Initial supports.....	5
4. Spacing requirements for services	6
5. Included products	7
5.1 Declarations of Performance.....	8
6. Design	9
6.1 Fire resistance classes.....	9
6.2 Pipe end configurations.....	9
7. Design variants	9
8. Fire protection measures	10
8.1 Cables / cable bundles / cable support structures	10
8.2 Non-combustible pipes.....	11
9. Installation steps.....	12

System Flammotect 4 × 60 mm

1. Preliminary remarks / overview

1.1 Use of the instructions

The installation instructions are intended solely for personnel trained in fire protection.

Before starting work, read through these installation instructions completely. Pay particular attention to the following safety instructions.

The authorisation holder assumes no liability for damage caused by failure to comply with these instructions.

Pictorial representations serve as examples only. Installation results may differ in appearance.

Upon request, flamro will be pleased to provide the relevant legal and technical framework and manufacturer specifications for each individual case.

1.2 Safety instructions

Consult the respective safety information for the individual penetration seal components.

Personal protective equipment:

	Wear protective clothing and non-slip shoes.
--	--

	Use safety goggles, safety glasses.
---	-------------------------------------

	P2 particle filter in case of short-term or low level exposure. Use breathing protection in compliance with international/national standards.
---	--

	Use chemically resistant gloves. Recommended materials: butyl rubber, nitrile rubber, fluorinated rubber, PVC.
---	---

Safety instructions for the installation of floor penetration seals

	The area below the floor penetration seal must be cordoned off against entry during penetration seal work (barrier tape and warning sign: warning of possible falling objects, do not enter the area, penetration seal work in floor openings).
---	---

	The contractor for the production of floor penetration seals must inform the client in writing (for forwarding to the client or appointed representative) that after the production of the fire penetration seals in floors, these must be secured on site against loads, in particular against being stepped on, by suitable measures (e.g. by fencing or by covering with grating).
---	---

System Flammotect 4 × 60 mm

1.3 Building elements

Rigid walls

Made of masonry, concrete, reinforced concrete, aerated concrete, ceramic blocks, hollow blocks or perforated blocks with a density of $\geq 600 \text{ kg/m}^3$.

The walls must be classified for the desired fire resistance duration according to EN 13501-2.

Rigid floors





Made of concrete.

The floors must be classified for the desired fire resistance duration according to EN 13501-2.

2. Allowed services

For specific fire resistance classes and pipe end configurations depending on measurements and fire protection measures see the respective chapters on design variants starting on page 9.

2.1 Cables

Service		Max. diameter [mm]
	Cables	≤ 80
	Cable bundles	≤ 100 , cable $\varnothing \leq 21$
	Cable trays	

2.2 Non-combustible pipes



Pipe material	Diameter [mm]
Steel, stainless steel, cast iron	≤ 323.9

System Flammotect 4 × 60 mm

3. Thicknesses, sizes and spacing

Dimensions		
	Wall [mm]	Floor [mm]
Thickness of building element	≥ 240	≥ 200
Thickness of penetration seal	≥ 240	≥ 240
Maximum dimensions of the aperture (width × height)	Cables: 600 × 600 Pipes: 400 × 400	600 × 1000 / 375 × ∞
Distance to other penetration seals	≥ 100	≥ 100
Distance to other apertures or installations	≥ 200	≥ 200

The total allowable cross section of the installations (outer dimensions) is ≤ 60% of the construction aperture.









3.1 Initial supports

Penetrating services must be supported at the distances specified in the table below. In wall constructions support is necessary on both sides. In floor constructions support is necessary on the upper side of the floor. Essential parts of the supports must be non-combustible.







Initial supports		
Service	Wall	Floor
Cables, cable bundles, cable support structures	≤ 100 mm	≤ 100 mm
Non-combustible pipes	≤ 950 mm	–

System Flammotect 4 × 60 mm

4. Spacing requirements for services

		   				Aperture edge		
		Single cables	Cable bundles	Cable support systems	Non-combustible pipes	Upper	Lower	Side
	Single cables	≥ 10 (horizontally) ≥ 80 (vertically)		≥ 100	≥ 20	≥ 0	≥ 20	
	Cable bundles	≥ 10 (horizontally) ≥ 80 (vertically)		≥ 100	≥ 20	≥ 0	≥ 20	
	Cable support systems	≥ 10 (horizontally) ≥ 80 (vertically)		≥ 100	≥ 20	≥ 0	≥ 20	
	Non-combustible pipes	≥ 100		≥ 100	≥ 40	≥ 40	≥ 40	

All specifications in mm. All specifications refer to distances between the respective insulations and additional measures if applicable.

		  			Aperture edge		
		Single cables	Cable bundles	Cable support systems	Upper	Lower	Side
	Single cables	≥ 10 (horizontally) ≥ 40 (vertically)		≥ 20	≥ 0	≥ 20	
	Cable bundles	≥ 10 (horizontally) ≥ 40 (vertically)		≥ 20	≥ 0	≥ 20	
	Cable support systems	≥ 10 (horizontally) ≥ 40 (vertically)		≥ 20	≥ 0	≥ 20	

All specifications in mm. All specifications refer to distances between the respective insulations and additional measures if applicable.

System Flammotect 4 × 60 mm

5. Included products



**FLAMMOTECT-A
Coating**

5 kg pail – Art. no. 01155132
12.5 kg pail – Art. no. 01155131



**FLAMMOTECT-A
Solid emulsion**

5 kg pail – Art. no. 01155121
12.5 kg pail – Art. no. 01155136



**FLAMMOTECT-A
Filler**

5 kg pail – Art. no. 01155135
12,5 kg pail – Art. no. 01155134
310 ml cartridge – Art. no. 01155115
600 ml flow pack – Art. no. 01155153

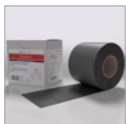

**DG-CR 1.5
Fire protection wrap**

Rolle, 10 m – Art. no. 01261931

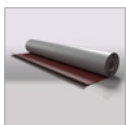

DG-CR 0.7

Fire protection cable bandage

Roll, 10 × 1100 mm – Art. no. 01260110
Roll, 20 × 1100 mm – Art. no. 01260231

Metal strap

100 × 15 mm – Art. no. 01234000

Fastening clamps

1000 pcs. – Art. no. 01234100

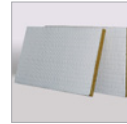

Mineral fibre boards

pre-coated on one side with
FLAMMOTECT-A
Dimensions 1000 × 600 × 60 mm
Box with 4 pcs. – Art. no. 01182165



**Mineral fibre board
in acc. with EN 13162**

Criteria: density ≥ 150 kg/m³
Reaction to fire class A1 in acc. with
EN 13501:1
Melting point ≥ 1000 °C.
(TR10) tensile strength vertical to board
surface ≥ 10 kPa according to EN 1607
Thickness ≥ 60 mm



Label

1 piece – Art. no. 14003

System Flammotect 4 × 60 mm

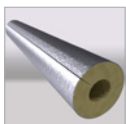

Lamella mat or pipe shells made of mineral fibres

Classification: A2-S1, d0 or A1 in acc. with EN 13501-1
 Minimum bulk density: 35 kg/m³
 Melting point ≥ 1000 °C

for example:

Name	Nominal bulk density [kg/m ³]	abP/DoP
Rockwool lamella mat Klimarock Roll, 3.05 m ² – Art. no. 01187100	40–50	DE0628031801 of 14.03.2018
Rockwool ProRox PS 960 (formerly Rockwool Lapimus pipe shell 880)	95–150	PROPS960NL-03
Rockwool 800	90–115	DE0721011801 of 15.01.2018
Rockwool ProRox WM 950 (formerly WM 80/RTD-2)	85	PROWM950D-03 of 04.05.2017
Rockwool ProRox WM WM 960 (formerly WM 100/ RBM)	100	PROWM960D-03 of 04.05.2017
Rockwool Conlit 150 U	150	P-NDS04-417
Isover Schalen Protect 1000 S, Isover Schalen Protect 1000 S Alu	70–90	DE0002-Pipe_Sections 001 of 10.06.2013
Isover mineral fibre mat MD2 and MD2/A	80	DE0002-Protect_EN14303 002 of 09.02.2015
Isover mineral fibre mat MDD and MDD/A	115	
PAROC Hvac Section AluCoat T	85–120	40361
PAROC Pro Section 100	100	40080
PAROC Hvac Lamella Mat AluCoat Fix	50	40236

5.1 Declarations of Performance

The Declarations of Performance for the featured products are available for download on our website:

<https://flamro.com/eu/downloads/>

System Flammotect 4 × 60 mm

6. Design

6.1 Fire resistance classes

System Flammotect 4 × 60 mm meets the requirements of max. class EI 240 in acc. with EN 13501-2.

The maximum fire resistance of penetration seals in vertical or horizontal enclosing building elements depends on the fire resistance class of the penetrating services. The fire resistance class of the sealing system is reduced to the fire resistance class of the installed service with the lowest fire resistance rating.

6.2 Pipe end configurations

Non-combustible pipes				
tested	included configurations			
	U/U	U/C	C/U	C/C
U/U	✓	✓	✓	✓
U/C	-	✓	✓	✓
C/U	-	-	✓	✓
C/C	-	-	-	✓

7. Design variants

The sealing system may be used to close apertures without installations (reserve penetration for subsequent configurations).

Pieces of the mineral fibre boards must be coated with FLAMMOTECT-A so that they are glued together.

The edges of the mineral fibre boards and/or the aperture edge must be coated with FLAMMOTECT-A so that the boards are glued to the building element.

Final coating of the outer board surface and a surrounding area of ≥ 25 mm with FLAMMOTECT-A (dry film thickness 2.0 mm). It is not necessary to glue the board layers together.

Sealing of annular gap:

≤ 5 mm by filling the entire depth with FLAMMOTECT-A,

> 5 mm by filling with loose mineral wool and coating with FLAMMOTECT-A (dry film thickness ≥ 1 mm).

Design variants for walls and floors

----- = Coating with FLAMMOTECT-A (dry film thickness ≥ 2.0)

All specifications in mm

System Flammotect 4 × 60 mm

8. Fire protection measures

8.1 Cables / cable bundles / cable support structures

Cables and cable bundles may be installed with or without cable trays.

Cable bundles may be installed unopened in the seal. It is not necessary to fill the interstices if the bundles consist of parallel-running cables that are tightly packed, tied, stitched or welded together.

The supporting structures for cable trays must be designed in such a way that the penetration seal will not be subjected to additional mechanical stress in case of fire.

Additionally, penetrating services must be wrapped with the fire protection wrap DG-CR 1.5.

The fire protection wrap DG-CR 1.5 is coated on one side and equipped with a protective film. The film must be removed before applying the wrap. The wrap is applied with the coated side facing inwards and fastened with steel wires.

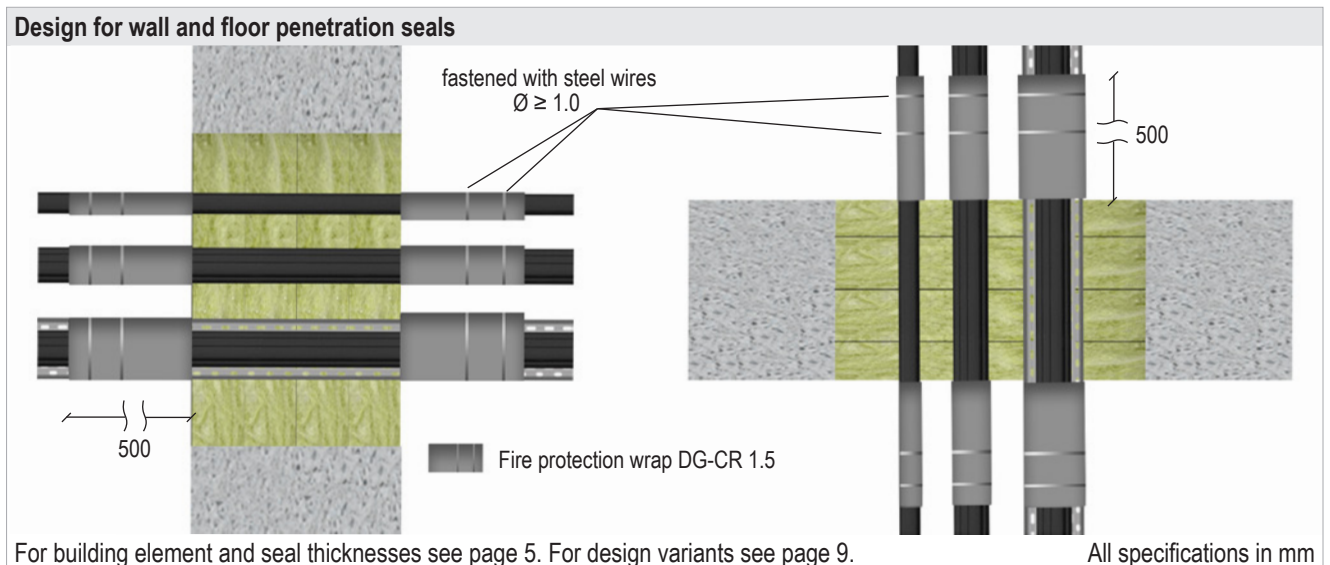

Service	Dimensions	Fire protection wrap DG-CR 1.5	Fire resistance class	
			Wall	Floor
Cables	Ø ≤ 80 mm	on each side 1 wrap with a width mit 500 mm or 5 wraps with a width of 125 mm and an overlap of 25 mm,	EI 240	EI 240
Cable bundles	Ø ≤ 100 mm with cables Ø ≤ 21 mm	2 layers each with an overlap of 50 mm	EI 240	EI 240

System Flammotect 4 × 60 mm

8.2 Non-combustible pipes

Pipes must be additionally wrapped on both sides with the fire protection cable bandage DG-CR 0.7 or the fire protection wrap DG-CR 1.5.

DG-CR 0.7 and DG-CR 1.5 are coated on one side and equipped with a protective film. The film must be removed before applying the bandage/wrap with the coated side facing inwards and fastening it with steel wires ($\varnothing \geq 1.0$).

Design for wall and floor penetration seals

fastened with steel wires $\varnothing \geq 1.0$

DG-CR 0.7 or DG-CR 1.5

Pipe shell made of mineral fibres (CS)
min. A2-s1,d0,
melting point ≥ 1000 °C,
bulk density ≥ 80 kg/m³

Lamella mat made of mineral fibres
min. A2,s1,d0;
melting point ≥ 1000 °C,
bulk density ≥ 35 kg/m³

For building element and seal thicknesses see page 5. For design variants see page 9. All specifications in mm

Pipe material	Outer \varnothing [mm]	Pipe wall thickness [mm]	Mineral fibre pipe shell		DG-CR 0.7 / 1.5 Length L_2 [mm]	Mineral fibre lamella mat		Fire resistance class
			Insulation length L_1 [mm]	Insulation thickness S_1 [mm]		Insulation length L_3 [mm]	Insulation thickness S_3 [mm]	
Steel, stainless steel, cast iron	≤ 42.4	2.3–14.2	750	50	500	500	30	EI 240 C/U
	≤ 88.9	2.9–14.2	1000	60		500	50	
	≤ 168.3	4.0–14.2	1250	70		750		
	≤ 219.1	4.5–14.2	1500	80	1000			
	≤ 323.9	5.6–14.2	1750	90	1000	1250		

System Flammotect 4 × 60 mm

9. Installation steps

1. Clean the aperture edge. Mask the aperture with crepe tape on all sides, keeping 25 mm distance to the edge.

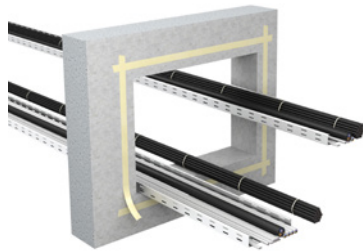

2. Cut mineral fibre boards to size (make cut-outs for the installations). Coat the edges of the mineral fibre boards with FLAMMOTECT-A and firmly place boards in position.

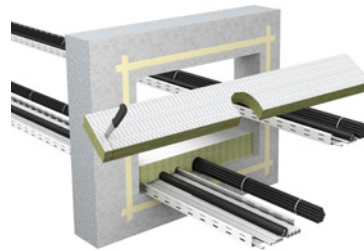

3. Seal the remaining opening/joints with mineral fibre or fill them with FLAMMOTECT-A.

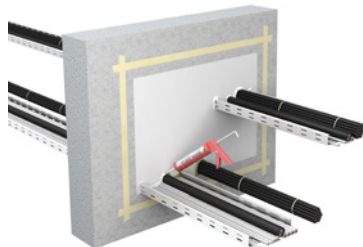

4. Wrap cables, cable bundles and cable support systems with DG-CR 0.7 or DG-CR 1.5.

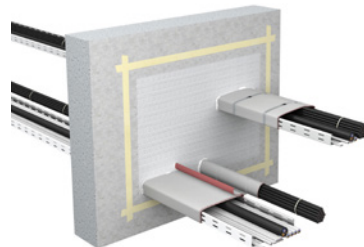

5. Final coating with FLAMMOTECT-A



6. If required, label the penetration seal. Fill out the label neatly and attach it firmly next to/above (not on) the penetration seal.

