

System Cable Tube

Cable penetration seal

Cable tube with click closure for sealing electrical cables and lines of all types, electrical installation conduits and other configurations; also for existing installations.

Maximum fire resistance class EI 120 in accordance with EN 13501-2 as per ETA-22/0053, KB 322042005-A and KB 321100703-A.

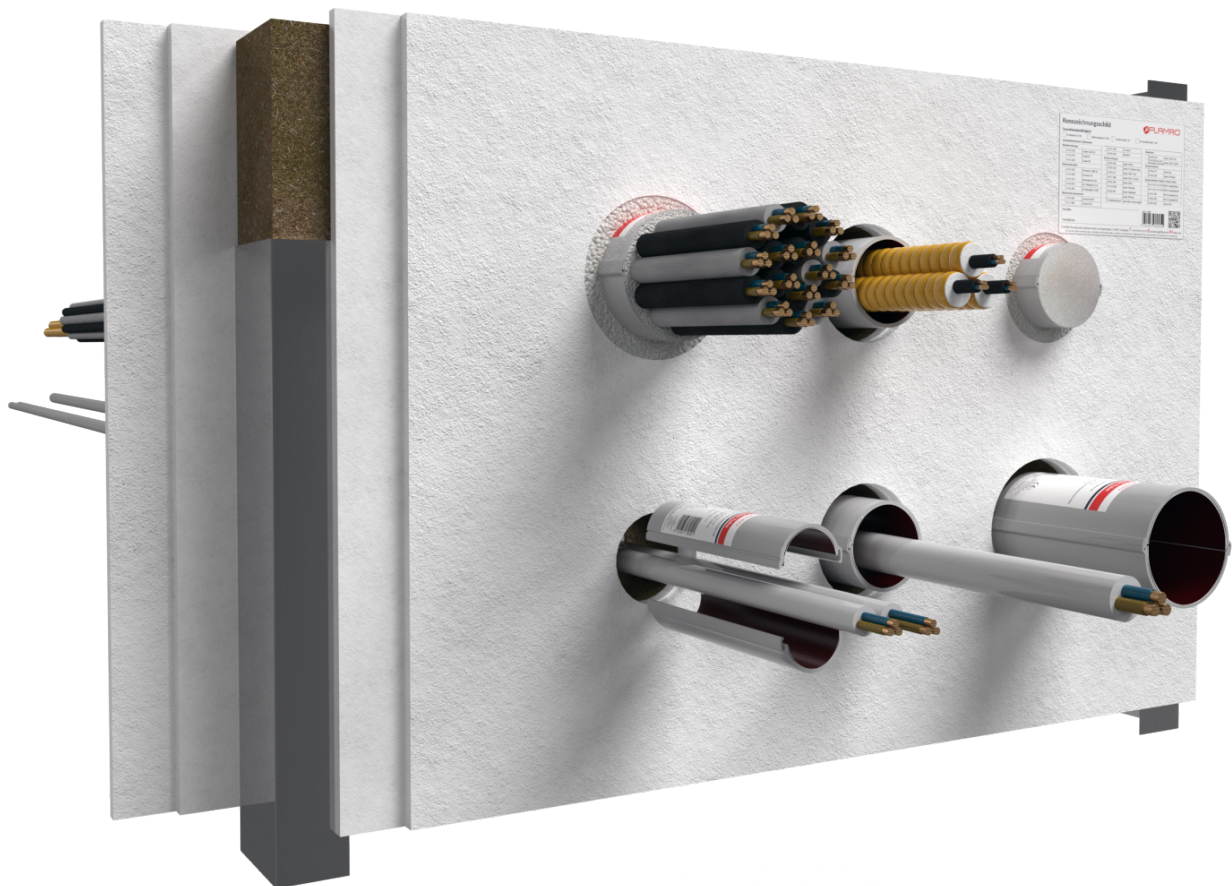

System Cable Tube

Table of contents

Topic	Page
1. Preliminary remarks / overview	3
1.1 Target group	3
1.2 Use of the instructions	3
1.3 Safety instructions	3
1.4 Field of application	4
1.5 Building elements	5
1.6 Thicknesses and spacing	6
2. Fire resistance classes	8
2.1 Walls	8
2.1.1 Timber walls	11
2.2 Floors	12
2.2.1 Timber floors	15
3. Allowed services	16
3.1 Cables / cable bundles / electrical installation conduits	16
3.2 Combustible pipes	16
3.3 Other services	17
4. Used products	18
5. Declarations of Performance	18
6. Design variants	19
6.1 First brackets/supports	20
7. Fire protection measures	21
7.1 Cables / cable bundles	21
7.2 Wave guides	23
7.3 Electrical installation conduits, single or bundled	24
7.4 speedpipes	26
7.5 HVAC split line combinations	27
7.6 Combustible pipes made of PVC-U	29
8. Installation steps	30

System Cable Tube

1. Preliminary remarks / overview

1.1 Target group

The installation instructions are intended solely for personnel trained in fire protection.

1.2 Use of the instructions

Before starting work, read through these installation instructions completely once. Pay particular attention to the following safety instructions.

The authorisation holder assumes no liability for damage caused by failure to comply with these instructions.

Pictorial representations serve as examples only. Installation results may differ in appearance.

Unless stated otherwise, all lengths are specified in mm.

All information in this document represents the state of the art at the time of writing or the current version of the standard.

Upon request, flamro will be pleased to provide the relevant legal and technical framework and manufacturer specifications for each individual case.

1.3 Safety instructions

The safety data sheets must be consulted when processing the penetration seal components.

Personal protective equipment:

	Wear protective clothing and non-slip shoes.
---	--

	Use safety goggles, safety glasses.
---	-------------------------------------

	Use protective mask with P2 particle filter in case of short-term or low level exposure. For intensive or prolonged exposure use a breathing apparatus with independent air supply. Use breathing protection in compliance with international/national standards.
---	---

	Use chemically resistant gloves. Recommended materials: butyl rubber, nitrile rubber, fluorinated rubber, PVC.
---	---

Safety instructions for the installation of floor penetration seals

	The area below the floor penetration seal must be cordoned off against entry during penetration seal work (barrier tape and warning sign: warning of possible falling objects, do not enter the area, penetration seal work in floor openings).
---	---

	The contractor for the production of floor penetration seals must inform the client in writing (for forwarding to the client or appointed representative) that after the production of the fire penetration seals in floors, these must be secured on site against loads, in particular against being stepped on, by suitable measures (e.g. by fencing or by covering with grating).
---	---

System Cable Tube

1.4 Field of application

The suitability for use of the System Cable Tube has been assessed in accordance with ETAG 026-2 in terms of the „Reaction to fire“, „Fire resistance“, „Release of dangerous substances“ and „Durability and serviceability“ product characteristics.

Reaction to fire

The ablative component FLAMMOTECT-A and the intumescent material DG-CR 1.5 SK meet class E for reaction to fire in accordance with EN 13501-1.

Fire resistance

System Cable Tube meets the maximum requirements of Class EI 120 (ending for plastic conduits –U/U) according to EN 13501-2.

The fire resistance classes for plastic conduits EI 120-U/U also covers all other possible endings according to EN 13501-2. When installed in walls or floors with a lower fire resistance rating, the fire resistance rating of the penetration is also reduced to that of the fire resistance rating of the wall or floor.

Release of dangerous substances

none

Durability and serviceability

The ablative component FLAMMOTECT-A and the intumescent fire protection fabric DG-CR 1.5 SK meet the requirements of type X for durability in accordance with EOTA TR 024.

System Cable Tube can be subjected to the conditions of interior rooms with and without exposure to moisture, with no substantial changes to the fire protection characteristics to be expected.

System Cable Tube

1.5 Building elements

Plasterboard walls with steel substructure

In stud design and double-sided cladding with at least 2 layers of 12.5 mm cement or gypsum-bound building boards with a reaction to fire of Class A1 or A2 according to EN 13501-1.

The walls must be classified for the required fire resistance rating in accordance with EN 13501-2.

Plasterboard walls with wood substructure

In stud design and double-sided cladding with at least 2 layers of 12.5 mm cement or gypsum-bound building boards with a reaction to fire of Class A1 or A2 according to EN 13501-1.

The distance between the opening and the studs and transoms must be ≥ 100 mm and the cavities between the cladding of the wall, studs and transoms and the opening reveal must be tightly sealed to a depth of ≥ 100 mm with mineral wool, reaction to fire Class A1 or A2 according to EN 13501-1.

The walls must be classified for the required fire resistance rating in accordance with EN 13501-2.

Solid walls

made of masonry, concrete, reinforced concrete or aerated concrete with a density of ≥ 450 kg/m³.

The walls must be classified for the required fire resistance rating in accordance with EN 13501-2.

Solid floors

made of concrete, reinforced concrete or aerated concrete with a density of ≥ 650 kg/m³.

The floors must be classified for the necessary fire resistance rating in accordance with EN 13501-2.

Timber walls and floors

Made of cross laminated timber (CLT) by the manufacturer STORA ENSO.

Wall: thickness 100 mm / layers: 30/40/30

Floor: thickness 140 mm / layers: 40/20/20/20/40

A wall or floor of cross laminated timber can be regarded as equivalent to the tested wall and floor if the following requirements are met.

- The construction of the wall/floor is identical.
- The fire resistance class of the wall/floor is identical or higher.
- The construction is certified as per EN 13501-2.
- The construction is based on the same solid wood panels as tested.
- The solid wood panels are of the same building material category as tested or of a better category.
- The strength class of the solid wood panels as per EN 338 is equivalent to the class of the tested panels or a higher class.
- The mass burning rate of the solid wood panels as per EN 1995-1-2 is equivalent to the class of the tested panels or a higher class.
- The thickness of the solid wood panel is at least equivalent to that of the tested panel.

Since particularly critical walls and floors were tested with this construction, we are also able to offer our sealing systems for timber components by other manufacturers, such as KLH, Mayr-Melnhof, Binderholz et al. Our technical service will be glad to assist you with any enquiry.

System Cable Tube

1.6 Thicknesses and spacing

Dimensions for single installations				
Pos.		Wall [mm]	Floor [mm]	Timber floor [mm]
A	Thickness of building element	≥ 100	≥ 125	≥ 140
B	Spacing distance to other System Cable Tubes in single installation	≥ 10	≥ 60	≥ 60
C	Annular gap size	≤ 25	≤ 25	≤ 25

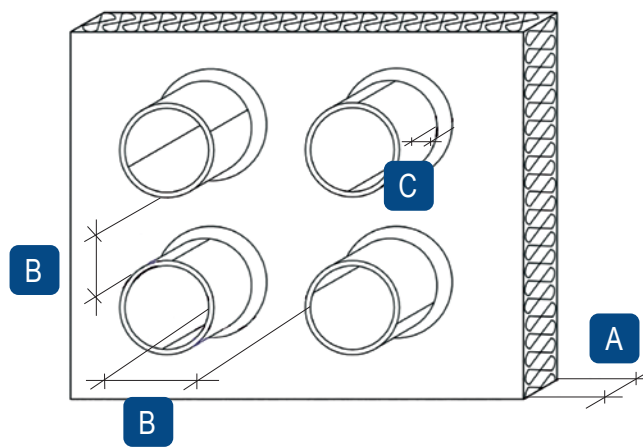

System Cable Tube

Dimensions for group installations (only in solid walls and floors)			
Pos.		Wall [mm]	Floor [mm]
A	Thickness of building element	≥ 100	≥ 150
B	Thickness of penetration seal	≥ 150	≥ 150
C	Maximum dimensions of the opening (width × height)	1200 × 2000	640 × ∞
D	Spacing distance next to each other / one above the other in group installations	≥ 3	≥ 10
E	Spacing distance to reveal	≥ 15	≥ 15
F	Spacing distance to other cable or pipe penetration seals	≥ 200	≥ 200
	one or both openings > 400 × 400 mm	≥ 100	≥ 100
G	Spacing distance to other openings or installations	≥ 200	≥ 200
	Spacing distance to other services in the same opening	cables, cable bundles, cable trays	≥ 65
H		other services	≥ 100
			≥ 100

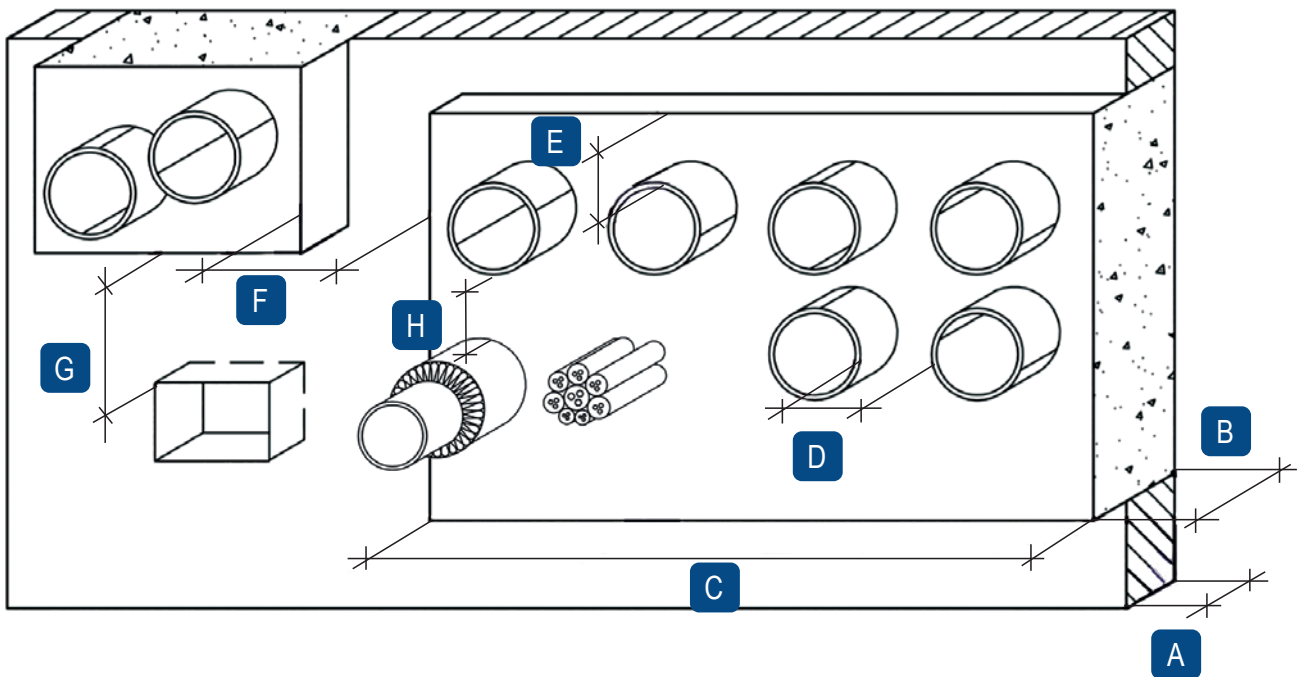

- The cable tubes may be completely filled with installations. The installations may be in contact with each other and the inner side of the cable tube.
- The total allowable cross section of the installations (outer dimensions) is ≤ 60% of the construction opening.

System Cable Tube

2. Fire resistance classes

2.1 Walls

Installation in walls			
Service	Measure	Fire resistance class	Source*
CT Cable Tube – length 150 mm			
Cables, cable bundles			
Cables $\varnothing \leq 21$ mm	–	EI 90 / E 120	1
Cable bundles $\varnothing \leq 100$ %, with cables $\varnothing \leq 21$ mm	–	EI 90 / E 120	1
Electrical installation conduits (EIC)			
Single EIC $\varnothing \leq 40$ mm, with/without cables $\varnothing \leq 21$ mm	–	EI 90 U/U E 120 U/U	9
EIC bundles, with/without cables $\varnothing \leq 90$ mm (consisting of EIC $\varnothing \leq 40$ mm, with/without cables $\varnothing \leq 21$ mm)	–	EI 90 U/U E 120 U/U	9
HVAC split line combinations			
Pipe $\varnothing 6-10$ mm / $10-18$ mm + PEF pipe insulation, thickness 9 mm + PE-100 outer $\varnothing \leq 25$ mm, s 1.5 mm (U/U) + max. 3 cables $\varnothing \leq 14$ mm	–	EI 90 U/U	2
speedpipes, bundled or single, with/without optical fibre cables			
7 mm $\leq \varnothing \leq 14$ mm bundle ≤ 100 %	–	EI 120 U/U	9

*Classification report no.:

1 → KB 02152/20/Z00NZNP, ,	2 → KB 1913.1/13/Z00NP,	3 → KB 3.2/11-104-1,	4 → KB 01883.2/14/Z00NP,
5 → KB K-3576/852/12-MPA BS,	6 → PB 3096/155/10-CR,	7 → KB 3.2/11-103-1,	8 → KB 00924.2/15/Z00NP.
9 → KB 319111905-A	10 → KB 322042005-A,	11 → KB 321100703-A	

Due to the available inner diameters in CT 60 and CT 90 it is not physically possible to install services of all sizes and diameters.

System Cable Tube

Installation in walls			
Service	Measure	Fire resistance class	Source*
CT Cable Tube – length 200 mm			
Cables, cable bundles			
Cables $\varnothing \leq 21$ mm	–	EI 120	1
Cable bundles $\varnothing \leq 100$ %, with cables $\varnothing \leq 21$ mm	–	EI 120	1
Electrical installation conduits (EIC)			
Single EIC $\varnothing \leq 40$ mm, with/without cables $\varnothing \leq 21$ mm	–	EI 120 U/U	9
EIC bundles, with/without cables $\varnothing \leq 90$ mm (consisting of EIC $\varnothing \leq 40$ mm, with/without cables $\varnothing \leq 21$ mm)	–	EI 120 U/U	9
EIC bundles $\varnothing \leq 100$ % (consisting of EIC $\varnothing \leq 32$ mm, with/without cables $\varnothing \leq 21$ mm)	–	EI 120 U/U	1
HVAC split line combinations			
pipe $\varnothing 6-10$ mm / $10-18$ mm + PEF pipe insulation, thickness 9 mm + PE-100 outer $\varnothing \leq 25$ mm, s 1.5 mm (U/U) + max. 3 cables $\varnothing \leq 14$ mm	–	EI 90 U/U	2
speedpipes, bundled or single, with/without optical fibre cables			
7 mm $\leq \varnothing \leq 14$ mm bundle ≤ 100 %	–	EI 120 U/U	9

*Classification report no.:

1 → KB 02152/20/Z00NZN,	2 → KB 1913.1/13/Z00NP,	3 → KB 3.2/11-104-1,	4 → KB 01883.2/14/Z00NP,
5 → KB K-3576/852/12-MPA BS,	6 → PB 3096/155/10-CR,	7 → KB 3.2/11-103-1,	8 → KB 00924.2/15/Z00NP.
9 → KB 319111905-A	10 → KB 322042005-A,	11 → KB 321100703-A	

System Cable Tube

Installation in walls			
Service	Measure	Fire resistance class	Source*
CT Cable Tube – length 300 mm			
Cables, cable bundles			
Cables $\varnothing \leq 21$ mm	–	EI 120	3
Cables $\varnothing \leq 50$ mm	–	EI 90 / E 120	3
Cables $\varnothing \leq 80$ mm	solid wall	EI 90 / E 120	3
Cable bundles $\varnothing \leq 100$ %, with cables $\varnothing \leq 21$ mm	–	EI 120	1
Wave guides			
CommScope HELIAX LDF (low density foam), $\varnothing \leq 16.002$ mm	–	EI 120 U/C	9
CommScope 50 Ω braided CNT, $\varnothing \leq 15.0$ mm	–	EI 120 U/C	
CommScope HELIAX AVA, $\varnothing \leq 28$ mm	–	E 120 U/C / EI 90 U/C	
CommScope HELIAX FSJ (super flexible), $\varnothing \leq 13.5$ mm	–	E 120 U/C / EI 90 U/C	
RFS RADIAFLEX RLK, $\varnothing \leq 28.5$ mm	–	EI 120 U/C	
RFS CELLFLEX LCF, $\varnothing \leq 27.8$ mm	–	EI 120 U/C	
Electrical installation conduits (EIC)			
EIC $\varnothing \leq 40$ mm, with/without cables $\varnothing \leq 21$ mm	–	E 120 U/U	9
EIC bundles, with/without cables (consisting of EIR $\varnothing \leq 40$ mm) $\varnothing \leq 90$ mm	–	E 120 U/U	9
EIC bundles $\varnothing \leq 100$ % (consisting of EIC $\varnothing \leq 32$ mm, with/without cables $\varnothing \leq 21$ mm)	–	EI 120 U/U	1
HVAC split line combinations			
pipe 1 / pipe 2 outer \varnothing 6–10 mm / 10–18 mm + PEF pipe insulation, thickness 9 mm + PE-100 outer $\varnothing \leq 25$ mm, s 1.5 mm (U/U) + max. 3 cables $\varnothing \leq 14$ mm	–	EI 90 U/U	2
speedpipes, bundled or single, with/without optical fibre cables			
7 mm $\leq \varnothing \leq 14$ mm bundle ≤ 100 %	–	EI 120 U/U	9
Combustible pipes made of PVC-U			
Pipe outer \varnothing 20 mm \times s 1.5 mm up to outer \varnothing 32 mm \times s 2.4 mm	–	EI 120 U/U	1

*Classification report no.:

1 → KB 02152/20/Z00NZN,
5 → KB K-3576/852/12-MPA BS,
9 → KB 319111905-A

2 → KB 1913.1/13/Z00NP,
6 → PB 3096/155/10-CR,
10 → KB 322042005-A,

3 → KB 3.2/11-104-1,
7 → KB 3.2/11-103-1,
11 → KB 321100703-A

4 → KB 01883.2/14/Z00NP,
8 → KB 00924.2/15/Z00NP.

System Cable Tube

2.1.1 Timber walls

Installation in timber walls			
Service	Measure	Fire resistance class	Source*
CT Cable Tube – length 150 mm			
Electrical installation conduits (EIC)			
EIC $\varnothing \leq 32$ mm (with/without cables)	–	EI 90 U/U	10
EIC bundles, with/without cables, $\varnothing \leq 3 \times 32$ mm	–	EI 90 U/U	10

*Classification report no.:

1 → KB 02152/20/Z00N ZP, ,

2 → KB 1913.1/13/Z00NP,

3 → KB 3.2/11-104-1,

4 → KB 01883.2/14/Z00NP,

5 → KB K-3576/852/12-MPA BS,

6 → PB 3096/155/10-CR,

7 → KB 3.2/11-103-1,

8 → KB 00924.2/15/Z00NP.

9 → KB 319111905-A

10 → KB 322042005-A,

11 → KB 321100703-A

System Cable Tube

2.2 Floors

Installation in floors			
Service	Measure	Fire resistance class	Source*
CT Cable Tube – length 150 mm			
Cables, cable bundles			
Cables Ø ≤ 21 mm	–	EI 120	4
Cables Ø ≤ 50 mm	only when 100% services are installed	EI 90 / E 90	6
Cable bundles Ø ≤ 100 %, with cables Ø ≤ 14 mm	–	EI 90	5
Cable bundles Ø ≤ 100 %, with cables Ø ≤ 21 mm	–	EI 60 / E 90	
	DG-CR 1.5, 1× 1 layer, 50 mm overlap, above and below floor	EI 120	4
Electrical installation conduits (EIC)			
EIC Ø ≤ 32 mm, with/without cables Ø ≤ 14 mm	max. 3 pcs.	EI 90 U/U	2
HVAC split line combinations			
Pipe Ø 6–10 mm / 10–18 mm + PEF pipe insulation, thickness 9 mm + PE-100 outer Ø ≤ 25 mm, s 1.5 mm (U/U) + max. 3 cables Ø ≤ 14 mm	–	EI 90 U/U	2
Pipe 1 / pipe 2 Outer Ø 6–22 mm / 6–22 mm + PEF pipe insulation, thickness 9 mm + PE-100 outer Ø ≤ 25 mm, s 1.5 mm (U/U) + max. 3 cables Ø ≤ 14 mm	lamella mat ≥ 250 mm × ≥ 30 mm above floor	EI 120 U/U	4
speedpipes, bundled or single, with/without optical fibre cables			
max. 24 pcs. pipe outer Ø ≤ 7 max. 7 pcs. pipe outer Ø ≤ 10 max. 5 pcs. pipe outer Ø ≤ 12	–	EI 120 U/U	4

*Classification report no.:

1 → KB 02152/20/Z00NZN,
5 → KB K-3576/852/12-MPA BS,
9 → KB 319111905-A

2 → KB 1913.1/13/Z00NP,
6 → PB 3096/155/10-CR,
10 → KB 322042005-A,

3 → KB 3.2/11-104-1,
7 → KB 3.2/11-103-1,
11 → KB 321100703-A

4 → KB 01883.2/14/Z00NP,
8 → KB 00924.2/15/Z00NP.

System Cable Tube

Installation in floors			
Service	Measure	Fire resistance class	Source*
CT Cable Tube – length 200 mm			
Cables, cable bundles			
Cables $\varnothing \leq 21$ mm	–	EI 120	4
Cables $\varnothing \leq 50$ mm	only when 100% services are installed	EI 90 / E 90	6
Cable bundles $\varnothing \leq 100$ %, with cables $\varnothing \leq 14$ mm	–	EI 120	4
Cable bundles $\varnothing \leq 100$ %, with cables $\varnothing \leq 21$ mm	–	EI 60 / E 90	5
	DG-CR 1.5, 1x 1 layer, 50 mm overlap, above and below floor	EI 120	4
Electrical installation conduits (EIC)			
EIC $\varnothing \leq 32$ mm, with/without cables $\varnothing \leq 14$ mm	max. 3 pcs.	EI 90 U/U	2
HVAC split line combinations			
Pipe 1 / pipe 2 Pipe \varnothing 6–10 mm / 10–18 mm + PEF pipe insulation, thickness 9 mm + PE-100 outer $\varnothing \leq 25$ mm, s 1.5 mm (U/U) + max. 3 cables $\varnothing \leq 14$ mm	–	EI 90 U/U	2
Pipe 1 / pipe 2 Outer \varnothing 6–22 mm / 6–22 mm + PEF pipe insulation, thickness 9 mm + PE-100 outer $\varnothing \leq 25$ mm, s 1.5 mm (U/U) + max. 3 cables $\varnothing \leq 14$ mm	lamella mat ≥ 250 mm \times ≥ 30 mm above floor	EI 120 U/U	4
speedpipes, bundled or single, with/without optical fibre cables			
max. 24 pcs. pipe outer $\varnothing \leq 7$ max. 7 pcs. pipe outer $\varnothing \leq 10$ max. 5 pcs. pipe outer $\varnothing \leq 12$	–	EI 120 U/U	4

*Classification report no.:

1 → KB 02152/20/Z00NZP,
5 → KB K-3576/852/12-MPA BS,
9 → KB 319111905-A

2 → KB 1913.1/13/Z00NP,
6 → PB 3096/155/10-CR,
10 → KB 322042005-A,

3 → KB 3.2/11-104-1,
7 → KB 3.2/11-103-1,
11 → KB 321100703-A

4 → KB 01883.2/14/Z00NP,
8 → KB 00924.2/15/Z00NP.

System Cable Tube

Installation in floors			
Service	Measure	Fire resistance class	Source*
CT Cable Tube – length 300 mm			
Cables, cable bundles			
Cables $\varnothing \leq 21$ mm	–	EI 120	4
Cables $\varnothing \leq 50$ mm	–	EI 60 / E 120	7
	only when 100% services are installed	EI 90 / E 90	6
	lamella mat ≥ 100 mm \times ≥ 30 mm + DG-CR 1.5, 1 \times 1 layer, above floor	EI 120	6
Cables $\varnothing \leq 80$ mm	–	EI 60 / E 120	7
Cable bundles $\varnothing \leq 100$ %, with cables $\varnothing \leq 21$ mm	–	EI 120	7
Electrical installation conduits (EIC)			
EIC bundles $\varnothing \leq 100$ % with EIC $\varnothing \leq 32$ mm, with/without cables $\varnothing \leq 21$ mm	floor ≥ 200 mm	EI 120 U/U	4
EIC $\varnothing \leq 63$ mm with/without cables $\varnothing \leq 21$ mm	–	EI 120 U/U	8
HVAC split line combinations			
Pipe 1 / pipe 2 Pipe \varnothing 6–10 mm / 10–18 mm + PEF pipe insulation, thickness 9 mm + PE-100 outer $\varnothing \leq 25$ mm, s 1.5 mm (U/U) + max. 3 cables $\varnothing \leq 14$ mm	–	EI 90 U/U	2
Pipe 1 / pipe 2 Outer \varnothing 6–22 mm / 6–22 mm + PEF pipe insulation, thickness 9 mm + PE-100 outer $\varnothing \leq 25$ mm, s 1.5 mm (U/U) + max. 3 cables $\varnothing \leq 14$ mm	lamella mat ≥ 250 mm \times ≥ 30 mm above floor	EI 120 U/U	4
speedpipes, bundled or single, with/without optical fibre cables			
max. 24 pcs. pipe outer $\varnothing \leq 7$ max. 7 pcs. pipe outer $\varnothing \leq 10$ max. 5 pcs. pipe outer $\varnothing \leq 12$	–	EI 120 U/U	4

*Classification report no.:

1 → KB 02152/20/Z00NZN,
5 → KB K-3576/852/12-MPA BS,
9 → KB 319111905-A

2 → KB 1913.1/13/Z00NP,
6 → PB 3096/155/10-CR,
10 → KB 322042005-A,

3 → KB 3.2/11-104-1,
7 → KB 3.2/11-103-1,
11 → KB 321100703-A

4 → KB 01883.2/14/Z00NP,
8 → KB 00924.2/15/Z00NP.

System Cable Tube

2.2.1 Timber floors

Installation in timber floors			
Service	Measure	Fire resistance class	Source*
CT Cable Tube – length 150 mm			
Cables, cable bundles			
Cables $\varnothing \leq 21$ mm	–	EI 90	11
Cable bundles $\varnothing \leq 100$ %	–	EI 90	11
Electrical installation conduits (EIC)			
EIC $\varnothing \leq 32$ mm, with/without cables	–	EI 90	11
EIC bundles $\varnothing \leq 3 \times 32$ mm, with/without cables	–	EI 90	11
HVAC split line combinations			
Copper pipe $\varnothing 2 \times 18$ mm (C/U) + PVC-U pipe outer $\varnothing \leq 25$ mm, s 4,5 mm (U/U) + cables $\varnothing \leq 14$ mm	–	EI 90	11

*Classification report no.:

1 → KB 02152/20/Z00N.ZP, ,

5 → KB K-3576/852/12-MPA BS,

9 → KB 319111905-A

2 → KB 1913.1/13/Z00NP,

6 → PB 3096/155/10-CR,

10 → KB 322042005-A,

3 → KB 3.2/11-104-1,

7 → KB 3.2/11-103-1,

11 → KB 321100703-A

4 → KB 01883.2/14/Z00NP,

8 → KB 00924.2/15/Z00NP.

System Cable Tube

3. Allowed services

3.1 Cables / cable bundles / electrical installation conduits



Electrical cables and lines of all types (including fibre optic cables)

The maximum size of the overall cross-section of the individual cables depends on the required fire resistance rating.

Wave guides



CommScope HELIAX LDF (low density foam) $\varnothing \leq 16.002$ mm
 CommScope 50 Ω braided CNT $\varnothing \leq 15.0$ mm
 CommScope HELIAX AVA $\varnothing \leq 28.0$ mm
 CommScope HELIAX FSJ (super flexible) $\varnothing \leq 13.5$ mm
 RFS RADIAFLEX RLK $\varnothing \leq 28.5$ mm
 RFS CELLFLEX LCF $\varnothing \leq 27.8$ mm

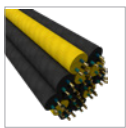

Cable bundles

$\varnothing \leq 100$ mm with single cable $\varnothing \leq 21$ mm.
 No filling of interstices necessary for tightly packed, tied cable bundles.



Electrical installation conduits made of plastic in accordance with EN 61386-22

With or without cables.
 Single up to outer $\varnothing 32$ mm ($\varnothing \leq 63$ mm in floors) or bundled up to outer $\varnothing \leq 100$ %, cable $\varnothing \leq 21$ mm.

3.2 Combustible pipes

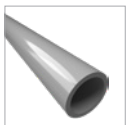

made of PVC in accordance with EN 1452 and DIN 8061/8062

Type of pipe	Pipe outer \varnothing [mm]	Pipe wall thickness [mm]
PVC	≤ 32	1.5–2.4

System Cable Tube

3.3 Other services

HVAC split line combinations



Double or single copper pipe (pipe 1 / pipe 2 outer Ø 6–22 mm / 6–22 mm)
 + PEF pipe insulation in accordance with EN 14313 (thickness 9 mm)
 + optional additional pipes (one plastic pipe (U/U) made of PVC-U, outer Ø 25 mm and pipe wall thickness 1.5 mm, in accordance with EN 1453-1 or EN1452-1 and DIN 8061 / DIN 8062 and up to 3 sheathed lines with a maximum number of 5 cores of $\leq 1.5 \text{ mm}^2$, $\text{Ø} \leq 14 \text{ mm}$) without spacing



speedpipes (PE pipes for optical fibre cables and micro cables)

made by Gabocom Systemtechnik GmbH, bundled or single, with/without optical fibre cable

Pipe outer Ø [mm]	Max. number [pcs.]	Pipe wall thickness [mm]
≤ 7	24	≤ 1.5
≤ 10	7	≤ 2.0
≤ 12	5	≤ 2.0

System Cable Tube

4. Used products



Cable Tube CT

comprising Cable Tube CT and 2 flexible foam plugs
 Ø 60 mm / L 150 mm – Art. no. 01276101
 Ø 90 mm / L 150 mm – Art. no. 01279101
 Ø 90 mm / L 200 mm – Art. no. 01279201
 Ø 90 mm / L 300 mm – Art. no. 01279301
 Ø 120 mm / L 150 mm – Art. no. 01281151
 Ø 120 mm / L 200 mm – Art. no. 01281201
 Ø 120 mm / L 300 mm – Art. no. 01281301



Foam plug set, spare plugs

Foam plugs:
 Ø 90 mm / 10 pieces in box – Art. no. 01279996
 Ø 120 mm / 10 pieces in box – Art. no. 01271996



FLAMMOTECT-A Filler

12.5 kg pail – Art. no. 01155134
 310 ml cartridge – Art. no. 01155115



NOVASIT BM Fire protection mortar

20 kg bag – Art. no. 01161000
 10 kg pail – Art. no. 01161010



GFM Fire protection mortar

Fibre-free ready-mix dry mortar M20 / MG III in accordance with EN 998-2
 25 kg bag – Art. no. 01167000



NOVASIT K2 Fire protection mortar

Fibre-free ready-mix dry mortar M20 / MG III in accordance with EN 998-2
 25 kg bag – Art. no. 01163000



Sealing material (independent of manufacturer)

Dimensionally stable, non-combustible (Class A1 or A2-s1,d0 in accordance with EN 13501-1) materials such as concrete, cement mortar, gypsum mortar



Lamella mat Klimarock

in accordance with DIN EN 14303 and DoP DE0628071802 dated 13.07.2018
 Reaction to fire class in accordance with EN 13501-1: Class A1
 Dimensions 610 × 50 cm, thickness 30 mm
 Roll of 3.05 m² – Art. no. 01187100
 It is allowed to apply any lamella mats / mineral fibre mats / mineral fibre pipe shells as long as they match the following requirements:
 EN 14303 bulk density ≥ 40 kg/m³
 Reaction to fire class A1 in acc. with EN 13501-1, thickness ≥ 30 mm



Mineral wool

Reaction to fire class in acc. with EN 13501-1: A1
 Melting point ≥ 1000 °C
 10 kg bag – Art. no. 01183000

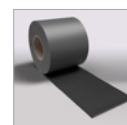

DG-CR 1.5 Fire protection wrap

Roll, 2.5 m × 125 mm - Art. no. 01261930
 Roll, 10 m × 125 mm – Art. no. 01261931

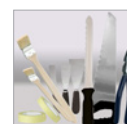

Recommended tools

filler, brush, masking tape, mineral wool knife and saw, if required: plastic film, folding ladder, lock wire pliers, steel wire (galvanised)

5. Declarations of Performance

The Declarations of Performance for featured Flamro products are available for download on our website:
<https://flamro.com/eu/downloads>

System Cable Tube

6. Design variants

- The cable tube may be used to close openings without installations (reserve penetration for subsequent configurations).
- When installing in plasterboard walls with a distance of more than 50 mm between the wall claddings on both sides of the steel substructure, secure the cable tubes with steel strapping or steel wires in the space between.
- When installing electrical installation conduits in plasterboard walls, ensure that the cable tubes protrude > 50 mm on each side and secure them additionally on both sides with steel strapping or steel wire.
- When installed in floors, the cable tubes must be flush with the underside of the floor and secured against loads/walking on by means of fencing or grating.

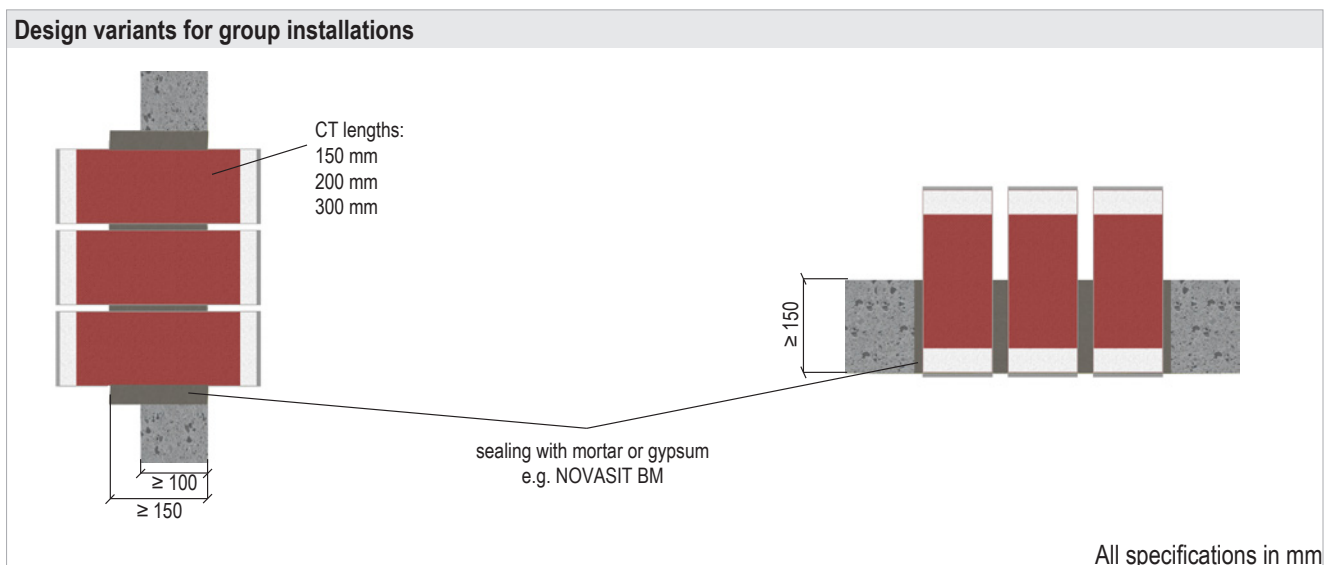
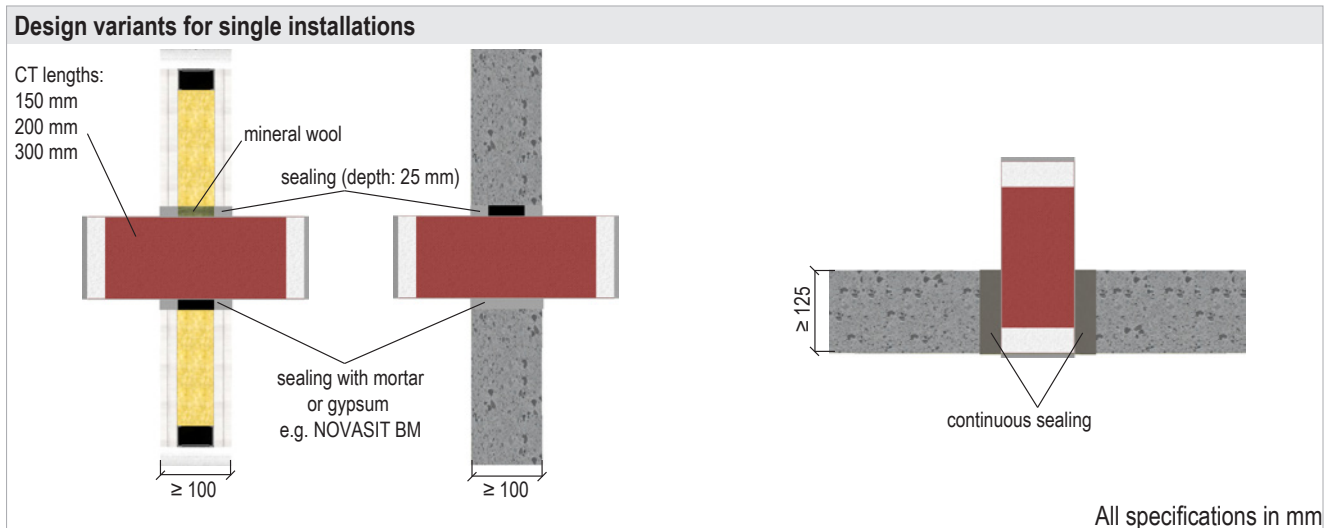

System Cable Tube

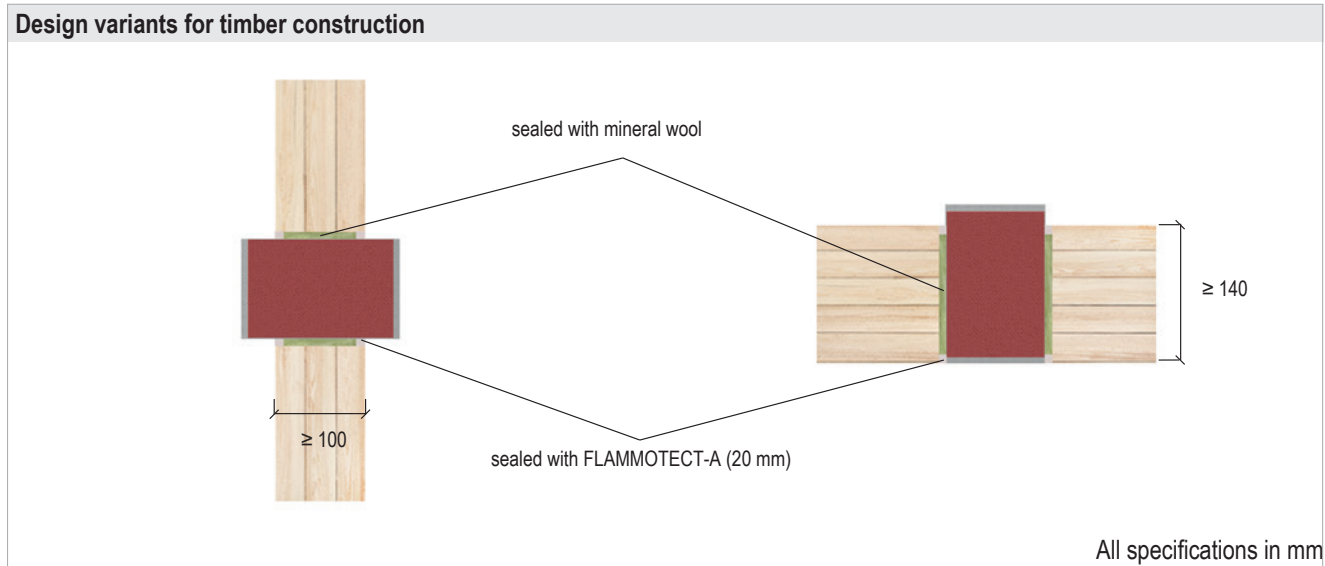

6.1 First brackets/supports

Essential parts of the brackets/supports for the installations used with the penetration sealing system must be non-combustible and installed at distances as follows:

Wall [mm] (on both sides)	Timber wall [mm] (on both sides)	Floor [mm] (above floor)
≤ 500	≤ 400	≤ 500

The first bracket (support) of the installations in front of the penetration sealing system must be made of steel or equivalent material.

System Cable Tube

7. Fire protection measures

The fire protection measures described on the following pages also apply to subsequent installations.

7.1 Cables / cable bundles

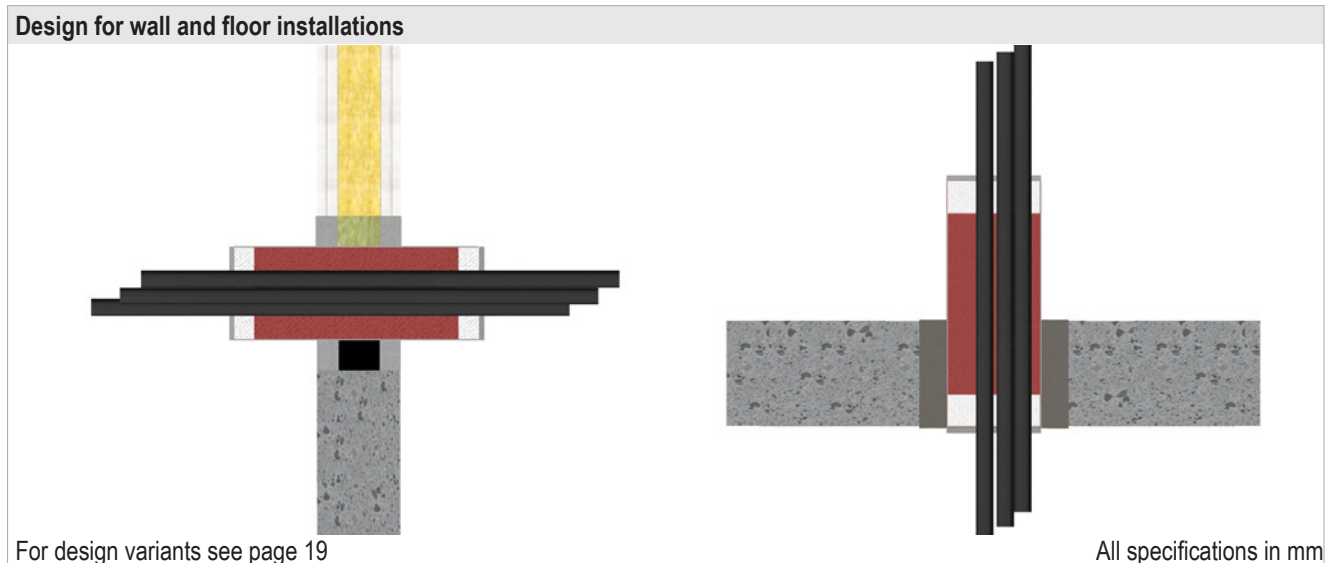

CT Cable Tube 150	Measure	Fire resistance classes		
		Wall	Floor	Timber floor
Cables $\varnothing \leq 21$ mm	–	EI 90 / E 120	EI 120	EI 90
Cables $\varnothing \leq 50$ mm	only when 100% services are installed	–	EI 90 / E 90	–
Cable bundles $\varnothing \leq 100$ %, with cables $\varnothing \leq 14$ mm	–	EI 90 / E 120	EI 120	EI 90
Cable bundles $\varnothing \leq 100$ %, with cables $\varnothing \leq 21$ mm	–	EI 90 / E 120	EI 60 / E 90	EI 90
Cable bundles $\varnothing \leq 100$ %, with cables $\varnothing \leq 21$ mm	DG-CR 1.5, 1× 1 layer + 50 mm overlap, above and below floor	–	EI 120	–

CT Cable Tube 200	Measure	Fire resistance classes	
		Wall	Floor
Cables $\varnothing \leq 21$ mm	–	EI 120	EI 120
Cables $\varnothing \leq 50$ mm	only when 100% services are installed	–	EI 90 / E 90
Cable bundles $\varnothing \leq 100$ %, with cables $\varnothing \leq 14$ mm	–	EI 120	EI 120
Cable bundles $\varnothing \leq 100$ %, with cables $\varnothing \leq 21$ mm	–	EI 120	EI 60 / E 90
Cable bundles $\varnothing \leq 100$ %, with cables $\varnothing \leq 21$ mm	DG-CR 1.5, 1× 1 layer + 50 mm overlap, above and below floor	–	EI 120

System Cable Tube

CT Cable Tube 300	Measure	Fire resistance classes	
		Wall	Floor
Cables $\varnothing \leq 21$ mm	–	EI 120	EI 120
Cables $\varnothing \leq 50$ mm	–	EI 90 / E 120	EI 60 / E 120
Cables $\varnothing \leq 50$ mm	only when 100% services are installed	–	EI 90 / E 90
Cables $\varnothing \leq 50$ mm	lamella mat ≥ 100 mm \times ≥ 30 mm + DG-CR 1.5, 1 \times 1 layer, above floor	–	EI 120
Cables $\varnothing \leq 80$ mm	only in solid walls and floors	EI 90 / E 120	EI 60 / E 120
Cable bundles $\varnothing \leq 100$ %, with cables $\varnothing \leq 21$ mm	–	EI 120	EI 120

System Cable Tube

7.2 Wave guides

Design for wall installations

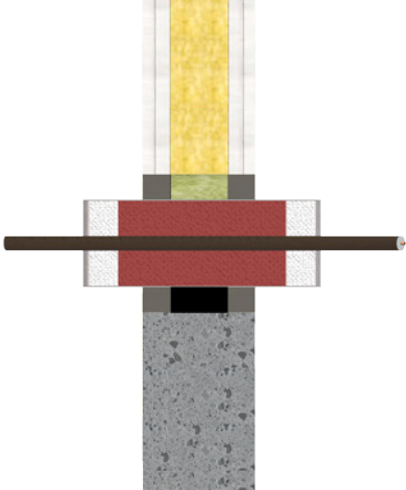

For design variants see page 19 All specifications in mm

CT Cable Tube 300	Measure	Fire resistance classes	
		Wall	Floor
CommScope HELIAX LDF (low density foam) Ø ≤ 16.002 mm	-	EI 120 U/C	-
CommScope 50Ω braided CNT Ø ≤ 15.0 mm	-	EI 120 U/C	-
CommScope HELIAX AVA Ø ≤ 28 mm	-	E 120 U/C / EI 90 U/C	-
CommScope HELIAX FSJ (super flexible) Ø ≤ 13.5 mm	-	E 120 U/C / EI 90 U/C	-
RFS RADIAFLEX RLK Ø ≤ 28.5 mm	-	EI 120 U/C	-
RFS CELLFLEX LCF Ø ≤ 27, 8 mm	-	EI 120 U/C	-

System Cable Tube

7.3 Electrical installation conduits, single or bundled

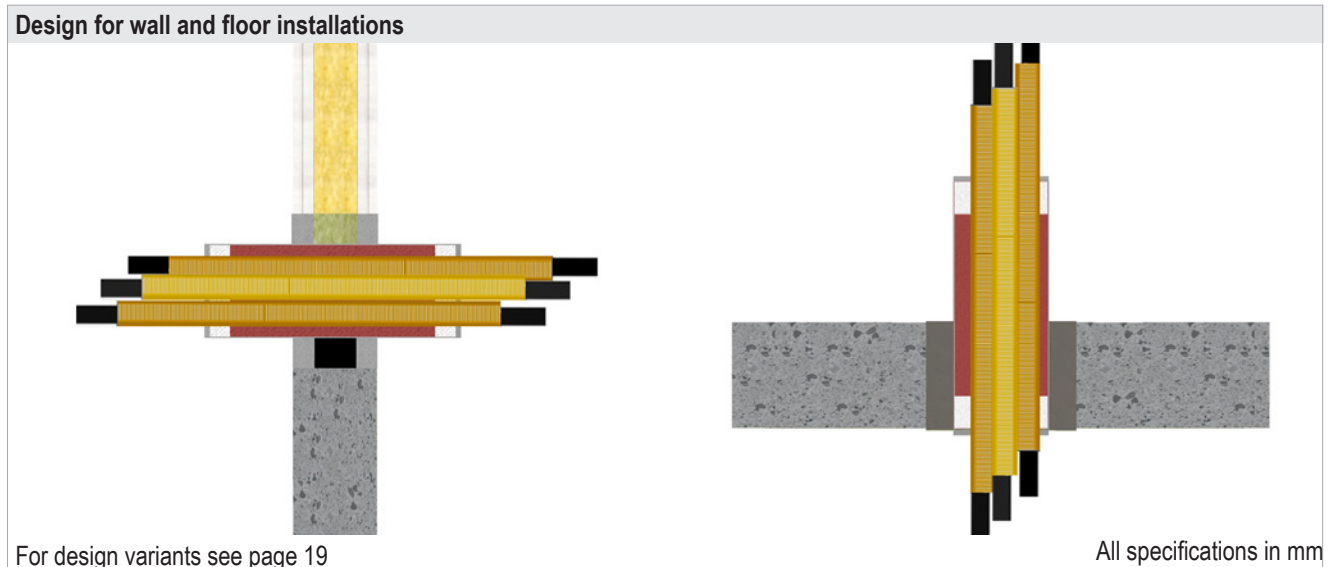

CT Cable Tube 150	Measure	Fire resistance classes			
		Wall	Timber wall	Floor	Timber floor
EIC single $\varnothing \leq 40$ mm, with/without cables $\varnothing \leq 21$ mm	–	EI 90 U/U E 120 U/U		–	
EIC bundles $\varnothing \leq 3 \times 32$ mm, with/without cables	max. 3 pcs.	–	EI 90 U/U	EI 90 U/U	EI 90
EIC bundles, with/without cables, $\varnothing \leq 90$ mm (consisting of EIC $\varnothing \leq 40$ mm, with/without cables $\varnothing \leq 21$ mm)	–	EI 90 U/U E 120 U/U		–	

CT Cable Tube 200	Measure	Fire resistance classes	
		Wall	Floor
EIC single $\varnothing \leq 40$ mm, with/without cables $\varnothing \leq 21$ mm	–	EI 120 U/U	–
EIC single $\varnothing \leq 32$ mm, with/without cables $\varnothing \leq 14$ mm	max. 3 pcs.	–	EI 90 U/U
EIC bundles, with/without cables, $\varnothing \leq 90$ mm (consisting of EIC $\varnothing \leq 40$ mm, with/without cables $\varnothing \leq 21$ mm)	–	EI 120 U/U	–
EIC bundles $\varnothing \leq 100$ % (consisting of EIC $\varnothing \leq 32$ mm, with/without cables $\varnothing \leq 21$ mm)	–	EI 120 U/U	–

System Cable Tube

CT Cable Tube 300	Measure	Fire resistance classes	
		Wall	Floor
EIC $\varnothing \leq 40$ mm / $\varnothing \leq 63$ mm, with/without cables $\varnothing \leq 21$ mm	$\varnothing \leq 40$ mm wall / $\varnothing \leq 63$ mm floor	EI 120 U/U	EI 120 U/U
EIC bundles, with/without cables (consisting of EIC $\varnothing \leq 40$ mm) $\varnothing \leq 90$ mm	–	EI 120 U/U	–
EIC bundles $\varnothing \leq 100$ % with EIC $\varnothing \leq 32$ mm, with/without cables $\varnothing \leq 21$ mm	wall ≥ 200 mm*	–	EI 120 U/U

* Instead of CT 300, two CT 150s connected with fabric tape can be used.

System Cable Tube

7.4 speedpipes

Design for wall and floor installations

For design variants see page 19 All specifications in mm

CT Cable Tube 150	Measure	Fire resistance classes	
		Wall	Floor
max. 24 pcs. pipe outer $\varnothing \leq 7$ max. 7 pcs. pipe outer $\varnothing \leq 10$ max. 5 pcs. pipe outer $\varnothing \leq 12$ bundle $\varnothing \leq 100\%$	-	EI 120 U/U	EI 120 U/U
CT Cable Tube 200	Measure	Fire resistance classes	
max. 24 pcs. pipe outer $\varnothing \leq 7$ max. 7 pcs. pipe outer $\varnothing \leq 10$ max. 5 pcs. pipe outer $\varnothing \leq 12$ bundle $\varnothing \leq 100\%$	-	EI 120 U/U	EI 120 U/U
CT Cable Tube 300	Measure	Fire resistance classes	
max. 24 pcs. pipe outer $\varnothing \leq 7$ max. 7 pcs. pipe outer $\varnothing \leq 10$ max. 5 pcs. pipe outer $\varnothing \leq 12$ bundle $\varnothing \leq 100\%$	-	EI 120 U/U	EI 120 U/U

System Cable Tube

7.5 HVAC split line combinations

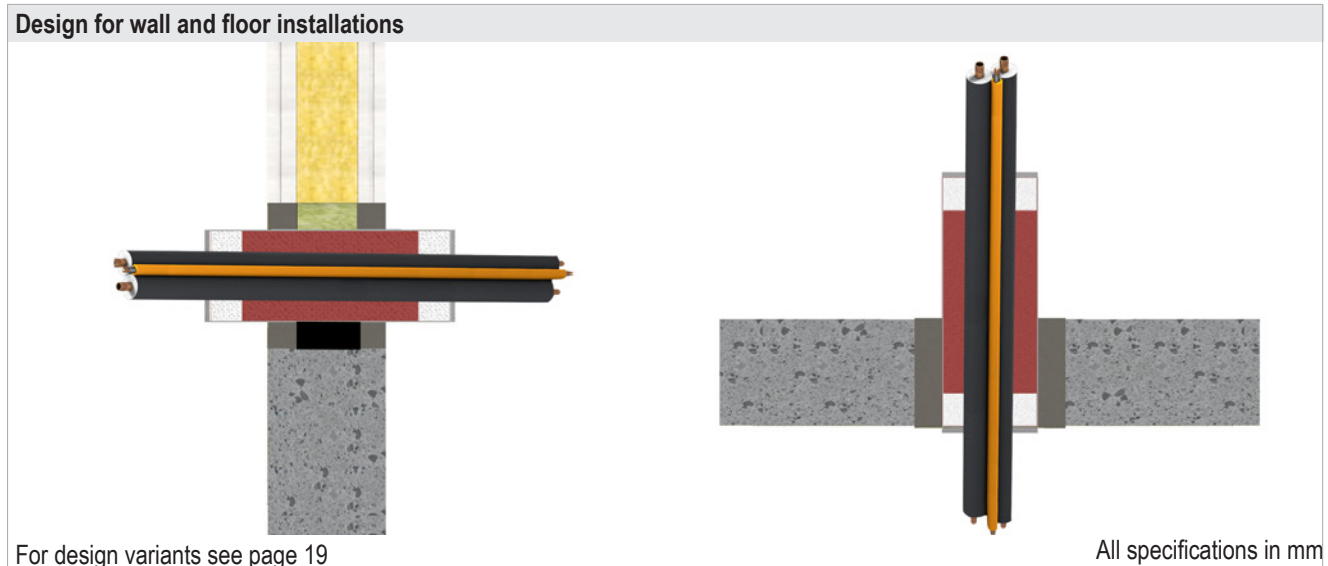

CT Cable Tube 150	Measure	Fire resistance classes		
		Wall	Floor	Timber floor
Pipe 1 / pipe 2 Pipe Ø 6–10 mm / 10–18 mm + PEF pipe insulation, thickness 9 mm + PE-100 outer Ø ≤ 25 mm, s 1.5 mm (U/U) + max. 3 cables Ø ≤ 14 mm	–	EI 90 U/U	EI 90 U/U	–
Copper pipe Ø 2 × 18 mm (C/U) + PVC-U pipe outer Ø ≤ 25 mm, s 4,5 mm (U/U) + cables Ø ≤ 14 mm	–	–	–	EI 90
Pipe 1 / pipe 2 outer Ø 6–22 mm / 6–22 mm + PEF pipe insulation, thickness 9 mm + PE-100 outer Ø ≤ 25 mm, s 1.5 mm (U/U) + max. 3 cables Ø ≤ 14 mm	lamella mat ≥ 250 mm × ≥ 30 mm above floor	–	EI 120 U/U	–

CT Cable Tube 200	Measure	Fire resistance classes	
		Wall	Floor
Pipe 1 / pipe 2 Pipe Ø 6–10 mm / 10–18 mm + PEF pipe insulation, thickness 9 mm + PE-100 outer Ø ≤ 25 mm, s 1.5 mm (U/U) + max. 3 cables Ø ≤ 14 mm	–	EI 90 U/U	EI 90 U/U
Pipe 1 / pipe 2 outer Ø 6–22 mm / 6–22 mm + PEF pipe insulation, thickness 9 mm + PE-100 outer Ø ≤ 25 mm, s 1.5 mm (U/U) + max. 3 cables Ø ≤ 14 mm	lamella mat ≥ 250 mm × ≥ 30 mm above floor	–	EI 120 U/U

System Cable Tube

CT Cable Tube 300	Measure	Fire resistance classes	
		Wall	Floor
Pipe 1 / pipe 2 Pipe Ø 6–10 mm / 10–18 mm + PEF pipe insulation, thickness 9 mm + PE-100 outer Ø ≤ 25 mm, s 1.5 mm (U/U) + max. 3 cables Ø ≤ 14 mm	–	EI 90 U/U	EI 90 U/U
Pipe 1 / pipe 2 Outer Ø 6–22 mm / 6–22 mm + PEF pipe insulation, thickness 9 mm + PE-100 outer Ø ≤ 25 mm, s 1.5 mm (U/U) + max. 3 cables Ø ≤ 14 mm	lamella mat ≥ 250 mm × ≥ 30 mm above floor	–	EI 120 U/U

System Cable Tube

7.6 Combustible pipes made of PVC-U

Design for wall installations

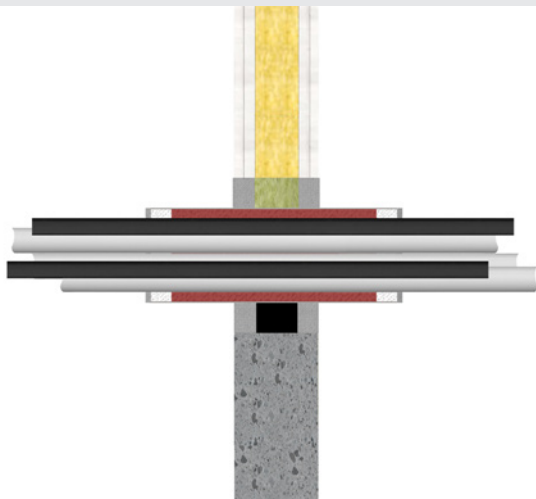

For design variants see page 19

All specifications in mm

CT Cable Tube 300	Measure	Fire resistance classes	
		Wall	Floor
2 PVC pipes $\varnothing \leq 32$ mm + 2 PVC pipes $\varnothing \leq 20$ mm + 3 additional cables $\varnothing \leq 14$ mm (5×1.5 mm ²)	-	EI 120 U/U	-

System Cable Tube

8. Installation steps

1. Insert the CT Cable Tube in the centre with the same length of protrusion on each side or place the half shells around the installations and connect them by clicking them together.

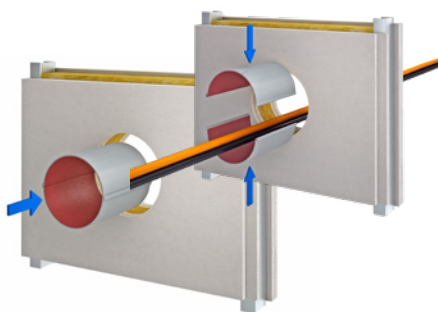

2. Seal the annular gap with NOVASIT BM / K2 or GFM.

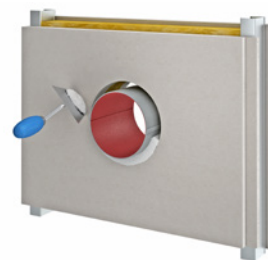

3. Carry out installations.

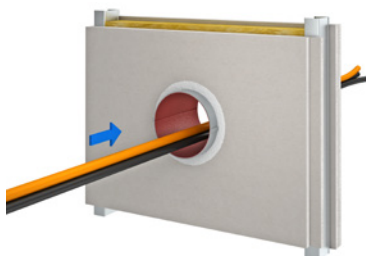

4. Cut plugs to size and fit them on both sides.

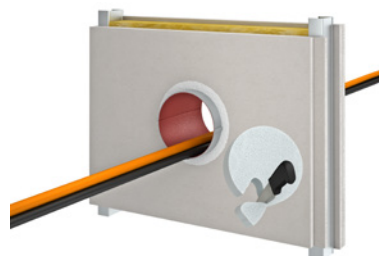

5. Seal the plugs completely at a depth of ≥ 2 mm (dry film thickness ≥ 1 mm) with FLAMMOTECT-A or BMK.

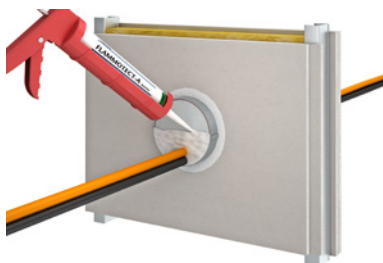

6. Label penetration seal if necessary or required.

