



ETA-Danmark A/S  
Göteborg Plads 1  
DK-2150 Nordhavn  
Tel. +45 72 24 59 00  
Internet [www.etadanmark.dk](http://www.etadanmark.dk)

Authorised and notified according  
to Article 29 of the Regulation (EU)  
No 305/2011 of the European  
Parliament and of the Council of 9  
March 2011

MEMBER OF EOTA



## European Technical Assessment ETA-15/0907 of 2024/11/04

### General Part

#### Technical Assessment Body issuing the ETA and designated according to Article 29 of the Regulation (EU) No 305/2011: ETA-Danmark A/S

Trade name of the  
construction product:

System FSC 4 Fire Stop Collar

Product family to which the  
above construction product  
belongs:

Fire Stopping and Sealing with penetration seals for  
pipes in walls and floors.

Manufacturer:

Flamro Brandschutz-Systeme GmbH  
Am Sportplatz 2  
DE-56291 Leiningen  
Tel +49 4105 4090 0  
Internet: [www.flamro.de](http://www.flamro.de)

Manufacturing plant:

Plant LEI

This European Technical  
Assessment contains:

17 pages including 3 annexes which form an integral  
part of the document

This European Technical  
Assessment is issued in  
accordance with Regulation  
(EU) No 305/2011, on the  
basis of:

EAD 350454-00-1104:  
Fire stopping and fire sealing products - Penetration  
seals

This version replaces:

The ETA with the same number issued on 2016-01-04

Translations of this European Technical Assessment in other languages shall fully correspond to the original issued document and should be identified as such.

Communication of this European Technical Assessment, including transmission by electronic means, shall be in full (excepted the confidential Annex(es) referred to above). However, partial reproduction may be made, with the written consent of the issuing Technical Assessment Body. Any partial reproduction has to be identified as such

## II SPECIFIC PART OF THE EUROPEAN TECHNICAL ASSESSMENT

### 1 Technical description of the product.

The System FSC 4 Fire Stop Collar pipe penetration seal, pipe collar with straps for plug fixing or embedding in mortar, gypsum. The System FSC 4 Fire Stop Collar pipe penetration seal consists of a metal casing of steel with a minimum thickness of 0,60 mm sufficiently protected against corrosion, and a fire protection lining located inside the housing. The lining consists of a 2 mm thick and 40 mm wide intumescent building material “ROKU® Strip EM” with a density of approx.  $1210 \pm 10 \text{ kg/m}^3$ .

The collars have an outer diameter of 61,2 mm up to 187,2 mm. The System FSC 4 Fire Stop Collar pipe penetration seal is permitted in lightweight partition walls and solid walls with a thickness of at least 100 mm and in solid floors with a thickness of at least 150 mm. The radial clearance between the penetrating plastic pipes – including insulation – and the vertical or horizontal building part closing off the room must be filled completely with mineral building materials.

Detailed specifications for identification and performance criteria relevant for fire safety regarding the construction products are given in annexes 1-3.

### 2 Specification of the intended use(s) in accordance with the applicable European Assessment Document (hereinafter EAD)

The construction product System FSC 4 Fire Stop Collar pipe penetration seal is intended for use as components with a fire protection effect in walls made from concrete, aerated concrete, masonry, or light weight partition structures that are subject to requirements related to fire protection. Their fire-resistant capability prevents heat transmission and fire spreading in the event of fire.

Within the scope of this ETA, the fire resistance was demonstrated for pipes in penetration seals which consisted of the components listed in table 1.

Table 1 – components of the verified penetration seals

Product type	Trade name
Collar	System FSC 4 Fire Stop Collar
Intumescent	Strip EM

Pipe penetration seals are used to seal off openings in fire resistant walls, which are penetrated by cables, and serves to preserve the walls' fire resistance around the penetrations.

Detailed information and data on the verified penetration seals are given in Annexes 1-3.

The performances given in Section 3 exclusively relate to this penetration seals (e.g. with respect to the design and arrangement of the components of the penetration seals and the type and position of the services, see annexes 1-3

The verification and assessment methods on which this European Technical Assessment is based lead to the assumption of a working life of at least 10 years for System FSC 4 Fire Stop Collar pipe penetration seal.

The indications given on the working life cannot be interpreted as a guarantee given by the manufacturer but are to be regarded only as a means for choosing the appropriate products in relation to the expected economically reasonable working life of the works.

### 3 Performance of the product and references to the methods used for its assessment

Characteristic	Assessment of characteristic
<b>3.2 Safety in case of fire (BWR 2)</b>	
Reaction to fire	The collar housing made of steel is classified as <b>Euroclass A1</b> in accordance with EN 13501-1 and delegated regulation 2016/364
	The intumescent material “ROKU® Strip EM” is classified as <b>Euroclass E</b> in accordance with EN 13501-1 and delegated regulation 2016/364
Resistance to fire	The System FSC 4 Fire Stop Collar pipe penetration seal used in penetrations seals as described in the annexes. Installation is permitted in lightweight partition walls and solid walls with a thickness of at least 100 mm and in solid ceilings with a thickness of at least 150 mm <b>is classified as described in annex 3</b> in accordance with EN 13501-2
<b>3.3 Hygiene, health and the environment (BWR 3)</b>	
Air permeability	<b>No performance assessed</b>
Water permeability	<b>No performance assessed</b>
Content, emission and/or release of dangerous substances*	<b>No performance assessed</b>
<b>3.4 Safety and accessibility in use (BWR 4)</b>	
Mechanical resistance and stability	<b>No performance assessed</b>
Resistance to impact/movement	<b>No performance assessed</b>
Adhesion	<b>No performance assessed</b>
Durability	<b>Use category Y<sub>1</sub></b>
<b>3.5 Protection against noise (BWR 5)</b>	
Airborne sound insulation	<b>No performance assessed</b>
<b>3.6 Energy economy and heat retention (BWR 6)</b>	
Thermal properties	<b>No performance assessed</b>
Water vapour permeability	<b>No performance assessed</b>

See additional information in section 3.8-3.9.

\*) In addition to the specific clauses relating to dangerous substances contained in this European technical Assessment, there may be other requirements applicable to the products falling within its scope (e.g., transposed European legislation and national laws, regulations and administrative provisions). In order to meet the provisions of the Construction Products Regulation, these requirements need also to be complied with, when and where they apply.

### **3.8 Methods of verification**

The assessment of system System FSC 4 Fire Stop Collar pipe penetration seal for the declared intended use has been made in accordance with EAD 350454-00-1104 Firestopping and fire sealing products, Penetration Seals, assessed as a collar according to table 1.1 of the EAD.

**3.9 General aspects related to the fitness for use of the product.** The verification of durability is part of testing the essential characteristics. The System FSC 4 Fire Stop Collar pipe penetration seal is intended for use at temperatures below 0 °C and with exposure to UV, but with no exposure to rain, and can therefore be categorized as Type Y<sub>1</sub>. Since the requirements for Type Y<sub>1</sub> are met, also the requirements for Type Y<sub>2</sub>, Z<sub>1</sub> and Z<sub>2</sub> are fulfilled.

Although a penetration seal is intended for indoor applications only, the construction process may result in it being subjected to more exposed conditions for a period before the building is closed. For this case provisions shall be made to protect temporarily exposed penetration seals according to the ETA-holder's installation instructions.

## **4 Assessment and verification of constancy of performance (hereinafter AVCP) system applied, with reference to its legal base**

### **4.1 AVCP system**

According to the decision 1999/454/EC of the European Commission, as amended by 2001/596/EC, the system(s) of assessment and verification of constancy of performance (see Annex V to Regulation (EU) No 305/2011) is 1.

## **5 Technical details necessary for the implementation of the AVCP system, as provided for in the applicable EAD**

Technical details necessary for the implementation of the AVCP system are laid down in the control plan deposited at ETA-Danmark prior to CE marking

Issued in Copenhagen on 2024-11-04 by



f./Thomas Bruun  
Managing Director, ETA-Danmark

**Annex 1**  
**Product details and definitions**

Product and performance of the System FSC 4 Fire Stop Collar pipe penetration seal system and accessory components:

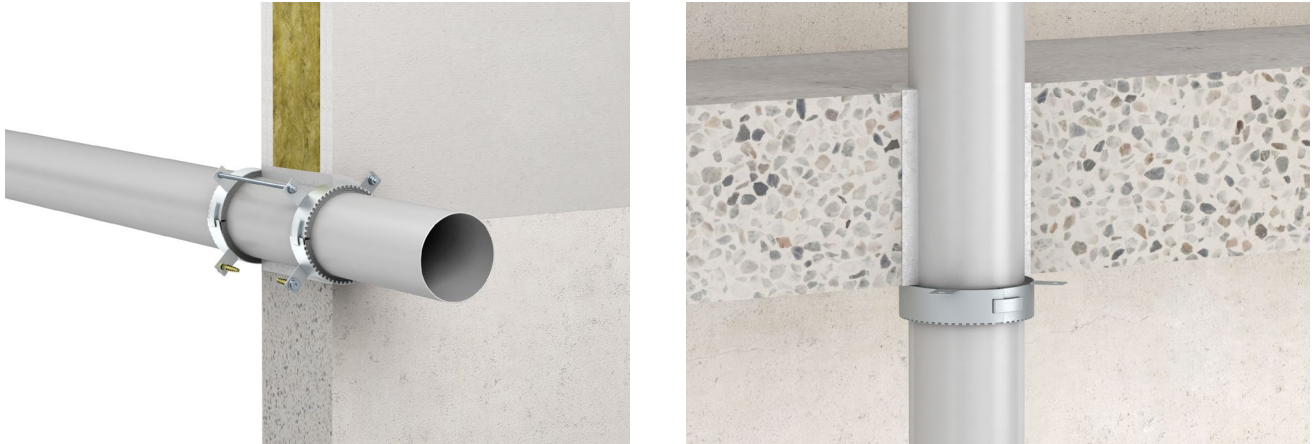

Product and performance of the ROKU® Strip EM:

Property	Parameter	Method
Weight loss on heating	52-62% (temperature 550 °C, 30 minutes)	TR 024 clause 3.1.8
Dimensions (thickness of the sheet)	2 mm ± 0,2mm	TR 024 clause 3.1.2
Density	1,02 -1,42 g/cm <sup>3</sup> (thickness 2 mm)	TR 024 clause 3.1.4
Expansion ratio	12-22,5 times	TR 024 clause 3.1.11
Expansion pressure	> 0,6 N/mm <sup>2</sup>	TR 024 clause 3.1.12

Product and performance of the System FSC 4 Fire Stop Collar pipe penetration seal system:

Manufacturer	Description
Flamro Brandschutz-Systeme GmbH Am Sportplatz 2 DE-56291 Leiningen	System FSC 4 Fire Stop Collar pipe penetration seal system. Pipe collar with straps for plug fixing or embedding in gypsum, mortar.

## Annex 2

### Detailed information and description of the test conditions under which the fire resistance performance was determined for the System FSC 4 Fire Stop Collar pipe penetration seal system

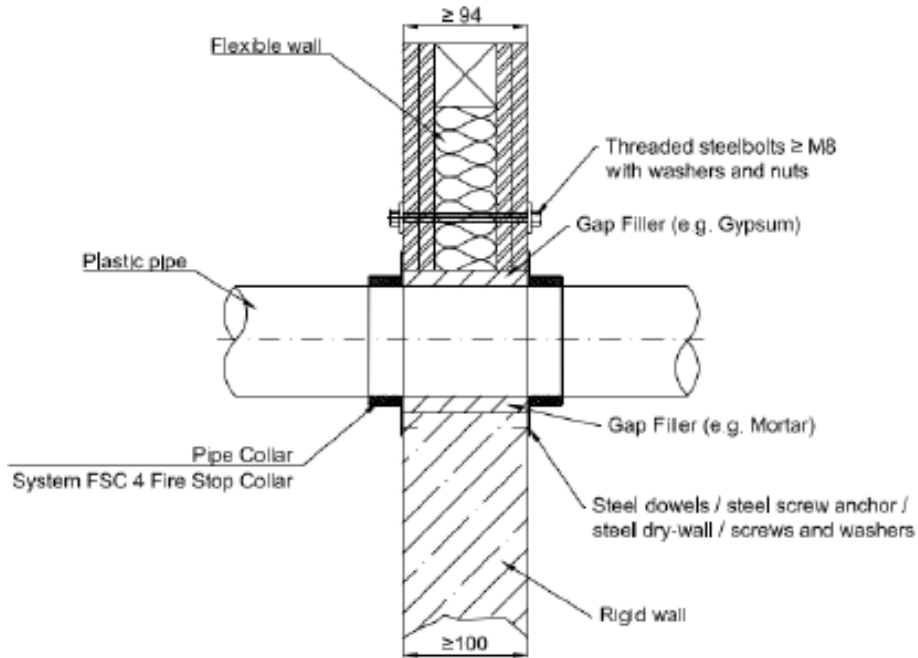

Penetration of pipes, wall installation - section view

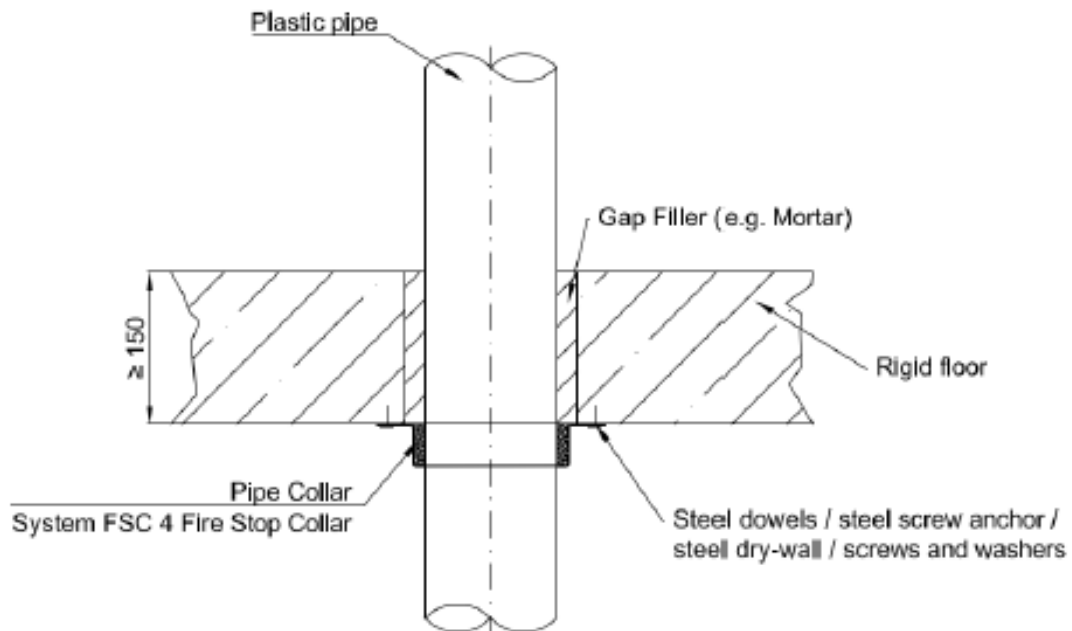

Penetration of pipes, floor installation - section view

**Annex 3****Description of the installations for the confirmation of fire resistance of penetration seal performance.**

The below applies to the tested seals as indicated in Annex 1 and/or Annex 2 for **100 mm light weight wall** construction with a standard value for fire resistance of 90 min according to EN 1366-3 clause 7.2.2.1.2.

Wall penetrations for pipe material <b>PVC-U</b> . Insulation without.									
Pipe $\phi$ (mm)	Wall thickness (mm)	Numbers of layers "ROKU® Strip EM"	Maximum achieved classification		Admissible pipe end configuration				Admissible collar lining
			E = Integrity and I = Insulation	E = Integrity	C/C	U/C	C/U	U/U	
$\leq 50$	1,8 - 5,6	2x2	EI 120 - U/C	E 120 - U/C	X	X			x
$> 50 - \leq 75$	1,8 - 8,4	2x3	EI 120 - U/C	E 120 - U/C	X	X			x
$> 75 - \leq 110$	1,8-12,3	2x4	EI 120 - U/C	E 120 - U/C	X	X			x
$> 110 - \leq 125$	2,2 - 12,2	2x5	EI 120 - U/C	E 120 - U/C	X	X			x
$\leq 160$	3,2-11,9	2x6	EI 120 - U/C	E 120 - U/C	X	X			x

Wall penetrations for pipe material <b>PE</b> . Insulation without.									
Pipe $\phi$ (mm)	Wall thickness (mm)	Numbers of layers "ROKU® Strip EM"	Maximum achieved classification		Admissible pipe end configuration				Admissible collar lining
			E = Integrity and I = Insulation	E = Integrity	C/C	U/C	C/U	U/U	
$\leq 50$	1,8 - 4,6	2x2	EI 120 - U/C	E 120 - U/C	X	X			x
$> 50 - \leq 75$	1,8 - 8,4	2x3	EI 120 - U/C	E 120 - U/C	X	X			x
$> 75 - \leq 110$	2,7-10,0	2x4	EI 120 - U/C	E 120 - U/C	X	X			x

Wall penetrations for pipe material <b>PP</b> . Insulation without.									
Pipe $\phi$ (mm)	Wall thickness (mm)	Numbers of layers "ROKU® Strip EM"	Maximum achieved classification		Admissible pipe end configuration				Admissible collar lining
			E = Integrity and I = Insulation	E = Integrity	C/C	U/C	C/U	U/U	
$\leq 50$	1,8 - 4,6	2x2	EI 120 - U/C	E 120 - U/C	X	X			x
$> 50 - \leq 75$	1,8 - 8,4	2x3	EI 120 - U/C	E 120 - U/C	X	X			x
$> 75 - \leq 110$	2,7-10,0	2x4	EI 120 - U/C	E 120 - U/C	X	X			x
$\leq 125$	3,9-12,2	2x5	EI 90 - U/C	E 90 - U/C	X	X			x
$\leq 160$	$> 4,0-14,6$	2x6	EI 90 - U/C	E 90 - U/C	X	X			x

Wall penetrations for pipe material <b>Blue Power</b> . Insulation without.									
Pipe $\varnothing$ (mm)	Wall thickness (mm)	Numbers of layers "ROKU® Strip EM"	Maximum achieved classification		Admissible pipe end configuration				Admissible collar lining
			E = Integrity and I = Insulation	E = Integrity	C/C	U/C	C/U	U/U	
≤ 50	1,8	2x2	EI 120 - U/C	E 120 - U/C	X	X			x
≤ 75	2,5	2x3	EI 120 - U/C	E 120 - U/C	X	X			x
≤ 110	3,4	2x4	EI 120 - U/C	E 120 - U/C	X	X			x

Wall penetrations for pipe material <b>Wavin SITECH</b> . Insulation without.									
Pipe $\varnothing$ (mm)	Wall thickness (mm)	Numbers of layers "ROKU® Strip EM"	Maximum achieved classification		Admissible pipe end configuration				Admissible collar lining
			E = Integrity and I = Insulation	E = Integrity	C/C	U/C	C/U	U/U	
≤ 50	2,0	2x2	EI 120 - U/C	E 120 - U/C	X	X			x
≤ 75	2,6	2x3	EI 90 - U/C	E 120 - U/C	X	X			x
≤ 110	3,6	2x4	EI 90 - U/C	E 120 - U/C	X	X			x

Wall penetrations for pipe material <b>aquatherm green pipe MS</b> . Insulation without.									
Pipe $\varnothing$ (mm)	Wall thickness (mm)	Numbers of layers "ROKU® Strip EM"	Maximum achieved classification		Admissible pipe end configuration				Admissible collar lining
			E = Integrity and I = Insulation	E = Integrity	C/C	U/C	C/U	U/U	
≤ 16	2,2	2x2	EI 120 - U/C	E 120 - U/C	X	X			x
≤ 50	6,9	2x2	EI 120 - U/C	E 120 - U/C	X	X			x
≤ 75	10,4	2x3	EI 120 - U/C	E 120 - U/C	X	X			x
≤ 110	15,2	2x4	EI 120 - U/C	E 120 - U/C	X	X			x

Also covered pipe diameter (mm) / wall thickness (mm)

20-2,8 / 25-3,5 / 32-4,5 / 40-5,6 / 63-8,7 / 90-12,5/

Wall penetrations for pipe material <b>Geberit Silent PP</b> . Insulation without.									
Pipe $\varnothing$ (mm)	Wall thickness (mm)	Numbers of layers "ROKU® Strip EM"	Maximum achieved classification		Admissible pipe end configuration				Admissible collar lining
			E = Integrity and I = Insulation	E = Integrity	C/C	U/C	C/U	U/U	
≤ 50	2,0	2x2	EI 120 - U/C	E 120 - U/C	X	X			x
≤ 75	2,6	2x3	EI 90 - U/C	E 120 - U/C	X	X			x
≤ 110	3,6	2x4	EI 90 - U/C	E 120 - U/C	X	X			x

Wall penetrations for pipe material <b>POLO-KAL NG</b> . Insulation without.									
Pipe $\varnothing$ (mm)	Wall thickness (mm)	Numbers of layers "ROKU® Strip EM"	Maximum achieved classification		Admissible pipe end configuration				Admissible collar lining
			E = Integrity and I = Insulation	E = Integrity	C/C	U/C	C/U	U/U	
≤ 50	2,0	2x2	EI 120 - U/C	E 120 - U/C	X	X			x
≤ 75	2,6	2x3	EI 90 - U/C	E 120 - U/C	X	X			x
≤ 110	3,4	2x4	EI 90 - U/C	E 120 - U/C	X	X			x
≤ 125	3,9	2x5	EI 120 - U/C	E 120 - U/C	X	X			x
≤ 160	4,9	2x6	EI 120 - U/C	E 120 - U/C	X	X			x

Wall penetrations for pipe material <b>Rehau Raupiano Plus</b> . Insulation without.									
Pipe $\varnothing$ (mm)	Wall thickness (mm)	Numbers of layers "ROKU® Strip EM"	Maximum achieved classification		Admissible pipe end configuration				Admissible collar lining
			E = Integrity and I = Insulation	E = Integrity	C/C	U/C	C/U	U/U	
≤ 50	1,8	2x2	EI 120 - U/C	E 120 - U/C	X	X			x
≤ 75	1,9	2x3	EI 120 - U/C	E 120 - U/C	X	X			x
≤ 110	2,7	2x4	EI 120 - U/C	E 120 - U/C	X	X			x
≤ 125	3,1	2x5	EI 120 - U/C	E 120 - U/C	X	X			x
≤ 160	3,6	2x6	EI 120 - U/C	E 120 - U/C	X	X			x

Wall penetrations for pipe material <b>Triplus 3 Schicht-Schallschutzrohr</b> . Insulation without.									
Pipe $\varnothing$ (mm)	Wall thickness (mm)	Numbers of layers "ROKU® Strip EM"	Maximum achieved classification		Admissible pipe end configuration				Admissible collar lining
			E = Integrity and I = Insulation	E = Integrity	C/C	U/C	C/U	U/U	
≤ 40	1,8	2x2	EI 120 - U/C	E 120 - U/C	X	X			x
≤ 75	2,5	2x3	EI 120 - U/C	E 120 - U/C	X	X			x
≤ 90	3,1	2x4	EI 120 - U/C	E 120 - U/C	X	X			x

The classification for the wall penetrations are declared under the following conditions:

<p>Field of application (Chapter 5.1 classification report)</p>	<p>Installation in walls: At least 100 mm thick standard lightweight wall construction with a standard value for fire resistance of 90 minutes according to EN1366-3. The above-mentioned pipe penetration seals may be mounted into all lightweight wall constructions of same fire resistance classification provided that:</p> <ul style="list-style-type: none"> <li>• The construction is classified according to EN 13501-2</li> <li>• The construction has a total thickness which is not less than the minimum thickness of the standard lightweight wall of 94-100 mm, that has been used in the test.</li> <li>• This regulation is not valid for pipe closure systems which are arranged within the supporting construction. In case of higher thickness of the supporting construction the length of the penetration seal must be increased by the same amount as the increased amount of wall. The distance to the surface of the supporting construction remains the same on both sides.</li> <li>• The number of panel layers is <math>\geq 2</math> and the total thickness of the panel layer is <math>\geq 25</math> when no soffit covering is used.</li> <li>• Lightweight construction walls with timber stud frame when the number of panel layers is <math>\geq 2</math> and the total thickness of the panel layer is <math>\geq 25</math>. No part of the penetration seal is allowed to be closer than 100 mm to a timber stud. The cavity between penetration seal and timber stud is closed by using 100 mm insulation classified as A1 or A2 according to EN 13501-1 which is put into the gap between seal and stud.</li> </ul>
	<p>The inside surface of the opening must be equipped with a lining.</p> <p>Walls made of concrete, aerated concrete or masonry with a wall thickness of <math>\geq 100</math></p> <p>The pipe penetration seals are only allowed to be designed as single penetration seals.</p> <p>The pipes are only allowed to be put through the penetration seal in a right angle.</p> <p>The first support (service support constructions) of the pipes both-sided of the separating element have to be arranged in a distance of <math>\leq 650</math> mm. The support must be non-combustible, according to EN 13501-1 Euro class A.</p> <p>The filling of the remaining gap (1-3 cm gap width) must be made in the thickness of the building element with gypsum/gypsum filing compound.</p>
<p>Distances</p>	<p>The minimum distance which has to be kept are:</p> <p>Distance between two single penetration seals of non-insulated pipes (distance from the pipe wall) <math>\geq 100</math> mm.</p> <p>Distance between two single penetration seals of insulated pipes (distance from the insulation) <math>\geq 100</math> mm</p>

The below applies to the tested seals as indicated in Annex 1 and/or Annex 2 for **floors made of concrete or aerated concrete with floor thickness of  $\geq 150$  mm and a density of  $\geq 550$  kg/m<sup>3</sup>** according to EN1366-3, clause 13.2.1

Floor penetrations for pipe material <b>PVC-U</b> . Insulation without.									
Pipe $\varnothing$ (mm)	Wall thickness (mm)	Numbers of layers "ROKU® Strip EM"	Maximum achieved classification		Admissible pipe end configuration				Admissible collar lining
			E = Integrity and I = Insulation	E = Integrity	C/C	U/C	C/U	U/U	
$\leq 50$	1,8 - 5,6	2	EI 240 - U/C	E 240 - U/C	X	X			x
$> 50 - \leq 75$	1,8 - 8,4	3	EI 240 - U/C	E 240 - U/C	X	X			x
$> 75 - \leq 110$	1,8-12,3	4	EI 240 - U/C	E 240 - U/C	X	X			x
$> 110 - \leq 125$	2,2 - 12,1	5	EI 120 - U/C	E 120 - U/C	X	X			x
$\leq 125$	12,1	5	EI 240 - U/C	E 240 - U/C	X	X			x
$\leq 160$	3,2-11,9	6	EI 120 - U/C	E 120 - U/C	X	X			x
$\leq 160$	11,9	6	EI 240 - U/C	E 240 - U/C	X	X			x

Floor penetrations for pipe material <b>PE</b> . Insulation without.									
Pipe $\varnothing$ (mm)	Wall thickness (mm)	Numbers of layers "ROKU® Strip EM"	Maximum achieved classification		Admissible pipe end configuration				Admissible collar lining
			E = Integrity and I = Insulation	E = Integrity	C/C	U/C	C/U	U/U	
$\leq 50$	1,8 - 4,6	2	EI 240 - U/C	E 240 - U/C	X	X			x
$> 50 - \leq 75$	1,8 - 8,4	3	EI 240 - U/C	E 240 - U/C	X	X			x
$> 75 - \leq 110$	2,7	4	EI 240 - U/C	E 240 - U/C	X	X			x
$> 75 - \leq 110$	$> 2,7-10,0$	4	EI 180 - U/C	E 240 - U/C	X	X			x
$\leq 125$	3,1	5	EI 240 - U/C	E 240 - U/C	X	X			x
$\leq 125$	$> 3,1-11,4$	5	EI 120 - U/C	E 240 - U/C	X	X			x
$\leq 160$	4	6	EI 240 - U/C	E 240 - U/C	X	X			x
$\leq 160$	$> 4,0-14,6$	6	EI 120 - U/C	E 240 - U/C	X	X			x

Floor penetrations for pipe material <b>PP</b> . Insulation without.									
Pipe $\varnothing$ (mm)	Wall thickness (mm)	Numbers of layers "ROKU® Strip EM"	Maximum achieved classification		Admissible pipe end configuration				Admissible collar lining
			E = Integrity and I = Insulation	E = Integrity	C/C	U/C	C/U	U/U	ROKU® Strip EM
$\leq 50$	1,8 - 4,6	2	EI 240 - U/C	E 240 - U/C	X	X			x
$> 50 - \leq 75$	1,8 - 8,4	3	EI 240 - U/C	E 240 - U/C	X	X			x
$> 75 - \leq 110$	2,7	4	EI 240 - U/C	E 240 - U/C	X	X			x
$> 75 - \leq 110$	$> 2,7-10$	4	EI 180 - U/C	E 180 - U/C	X	X			x

Floor penetrations for pipe material <b>Uponor MLC Rohr "weiß"</b> . Insulation without.									
Pipe $\varnothing$ (mm)	Wall thickness (mm)	Numbers of layers "ROKU® Strip EM"	Maximum achieved classification		Admissible pipe end configuration				Admissible collar lining
			E = Integrity and I = Insulation	E = Integrity	C/C	U/C	C/U	U/U	ROKU® Strip EM
$\leq 50$	4,5	2	EI 120 - U/C	E 120 - U/C	X	X			x
$\leq 75$	7,5	3	EI 90 - U/C	E 90 - U/C	X	X			x
$\leq 110$	10	4	EI 90 - U/C	E 90 - U/C	X	X			x
Also covered pipe diameter (mm) / wall thicknesses (mm)									
(14-18)x2,0 / 20x2,25 / 25x2,5 / 32x3,0 / 40 x 4,0 / 63x6,0 / 90x8,5									

Floor penetrations for pipe material <b>aquatherm green pipe MS</b> . Insulation without.									
Pipe $\varnothing$ (mm)	Wall thickness (mm)	Numbers of layers "ROKU® Strip EM"	Maximum achieved classification		Admissible pipe end configuration				Admissible collar lining
			E = Integrity and I = Insulation	E = Integrity	C/C	U/C	C/U	U/U	ROKU® Strip EM
$\leq 16$	2,2	2	EI 120 - U/C	E 120 - U/C	X	X			x
$\leq 50$	6,9	2	EI 120 - U/C	E 120 - U/C	X	X			x
$\leq 75$	10,4	3	EI 120 - U/C	E 120 - U/C	X	X			x
$\leq 110$	15,2	4	EI 120 - U/C	E 120 - U/C	X	X			x
Also covered pipe diameter (mm) / wall thicknesses (mm)									
20-2,8 / 25-3,5 / 32-4,5 / 40-5,6 / 63-8,7 / 90-12,5									

Floor penetrations for pipe material <b>Wavin SITECH</b> . Insulation without.									
Pipe ø (mm)	Wall thickness (mm)	Numbers of layers "ROKU® Strip EM"	Maximum achieved classification		Admissible pipe end configuration				Admissible collar lining
			E = Integrity and I = Insulation	E = Integrity	C/C	U/C	C/U	U/U	
≤ 50	2	2	EI 120 - U/C	E 120 - U/C	X	X			x
≤ 75	2,6	3	EI 120 - U/C	E 120 - U/C	X	X			x
≤ 110	3,6	4	EI 120 - U/C	E 120 - U/C	X	X			x
≤ 125	4,2	5	EI 60 - U/C	E 60 - U/C	X	X			x
≤ 160	5,3	6	EI 60 - U/C	E 60 - U/C	X	X			x

Floor penetrations for pipe material <b>Geberit Silent PP</b> . Insulation without.									
Pipe ø (mm)	Wall thickness (mm)	Numbers of layers "ROKU® Strip EM"	Maximum achieved classification		Admissible pipe end configuration				Admissible collar lining
			E = Integrity and I = Insulation	E = Integrity	C/C	U/C	C/U	U/U	
≤ 50	2	2	EI 120 - U/C	E 120 - U/C	X	X			x
≤ 75	2,6	3	EI 120 - U/C	E 120 - U/C	X	X			x
≤ 110	3,6	4	EI 120 - U/C	E 120 - U/C	X	X			x

Floor penetrations for pipe material <b>POLO-KAL NG</b> . Insulation without.									
Pipe ø (mm)	Wall thickness (mm)	Numbers of layers "ROKU® Strip EM"	Maximum achieved classification		Admissible pipe end configuration				Admissible collar lining
			E = Integrity and I = Insulation	E = Integrity	C/C	U/C	C/U	U/U	
≤ 50	2	2	EI 90 - U/C	E 120 - U/C	X	X			x
≤ 75	2,6	3	EI 90 - U/C	E 120 - U/C	X	X			x
≤ 110	3,6	4	EI 120 - U/C	E 120 - U/C	X	X			x

The classification is declared under the following conditions:

<p>Field of application (Chapter 5.2 classification report)</p>	<p>Floors made of concrete or aerated concrete with floor thickness of <math>\geq 150</math> mm and a density of <math>\geq 550</math> kg/m<sup>3</sup> according to EN1366-3, clause 13.2.1</p> <p>The filling of the remaining gap (1-5 cm gap width) must be carried out by using a casting compound with mineral construction material (class A1 or A2) such as cement mortar, gypsum etc.</p>
<p>Distances</p>	<p>The minimum distance which must be kept are:</p> <p>Distance between two single penetration seals of non-insulated pipes (distance from the pipe wall) <math>\geq 100</math> mm.</p> <p>Distance between two single penetration seals of insulated pipes (distance from the insulation) <math>\geq 100</math> mm</p>