



Through-penetration Firestop Systems

System No. HW-S-0143

ANSI/UL1479 (ASTM E814)

CAN / ULC S115

Assembly Rating – 3 Hr	F Rating – 3 Hr
Joint Width – 1 In. (25 mm) Max	FT Rating – 3 Hr
	FH Rating – 3 Hr
	FTH Rating – 3 Hr
	Joint Width – 1 In. (25 mm)

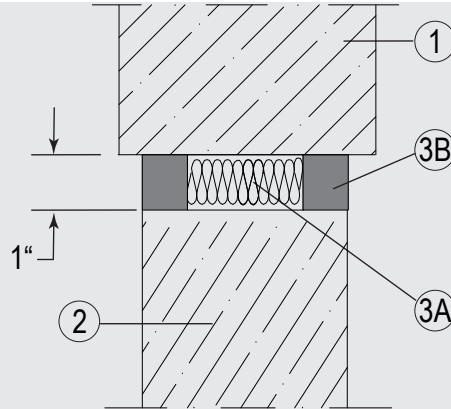

1. Floor or Wall Assembly

Min 4-1/2 in. (114 mm) thickness of reinforced lightweight or normal weight (100-150 pcf or 1600-2400 kg/m³) structural concrete. Floor may also be constructed of any 4.5 in. (114 mm) thick UL Classified hollow-core Precast Concrete Units*. See Precast Concrete Units (CFTV) category in the Fire Resistance Directory for names of manufacturers.

2. Wall Assembly

Min 4-1/2 in. (115 mm) thick reinforced lightweight or normal weight (100 - 150 pcf or 1600-2400 kg/m³) concrete. Wall may also be constructed of any UL Classified Concrete Blocks*. See Concrete Blocks (CAZT) category in the Fire Resistance Directory for names of manufacturers.

3. Joint System

Max separation between top of wall and bottom of floor is 1 in. (25 mm). The joint system shall consist of the following:

- A. Packing Material – Min 6-1/4 pcf (100 kg/m³) mineral wool batt insulation firmly packed into opening as a permanent form. Packing material to be recessed from both sides of wall to accommodate the required thickness of fill material.
- B. Fill, Void or Cavity Material* – Sealant – Min 2/5 in. (10 mm) thickness of fill material, installed on each side of the wall between the top of the wall and the bottom of the concrete floor, flush with each surface of the wall.

Flamro Brandschutz-Systeme GmbH – FLAMMOTECT-A

*Indicates such products shall bear the UL or cUL Certification Mark for jurisdictions employing the UL or cUL Certification (such as Canada), respectively. Reprinted from Product iQ with permission from UL Solutions. ©2024 UL LLC.