

Through-penetration Firestop Systems

System No. F-A-8046

ANSI/UL1479 (ASTM E814)	CAN / ULC S115
F Rating – 3 Hr	F Rating – 3 Hr
T Rating – 3 Hr	FT Rating – 3 Hr
	FH Rating – 3 Hr
	FTH Rating – 3 Hr

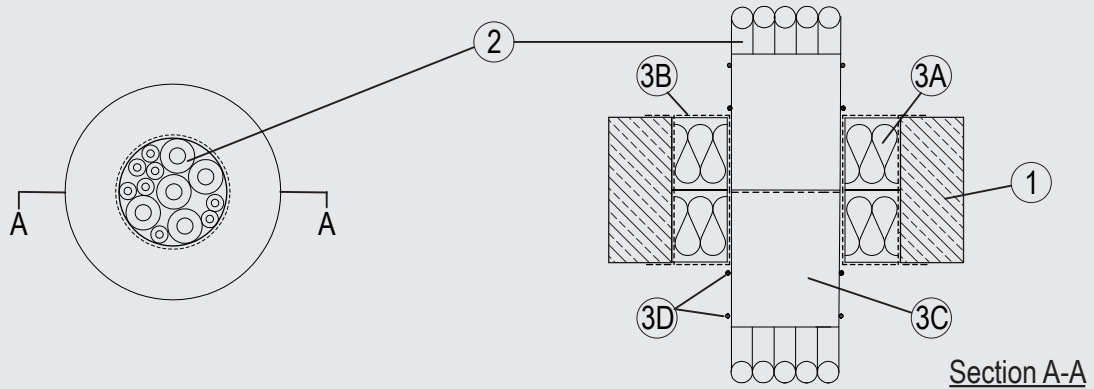

System tested with a pressure differential of 2.5 Pa between the exposed and the unexposed surfaces with the higher pressure on the exposed side.

1. Floor Assembly

Min. 4-1/2 in. (115 mm) thick lightweight or normal weight (100-150 pcf or 1600 - 2400 kg/m³) concrete. Opening shall be circular or rectangular with max diameter or dimensions of 7-7/8 in. (200 mm).

2. Services

1-1/4 in. (32 mm) diameter (or smaller) PE-HD conduit in bundles of diameter 4 in. (100 mm) or smaller, containing the following cables:

- A. Max 5/C No. 15 AWG (1.5 mm) diameter (or smaller), copper conductor cable with EPR insulation and Rubber jacket.
- B. Max 5/C No. 15 AWG (1.5 mm) diameter (or smaller), copper conductor cable with XPLE insulation and EVA jacket.
- C. Max 5/C No. 15 AWG (1.5 mm) diameter (or smaller), copper conductor cable with PVC insulation and PVC jacket.
- D. Max 20/C No. 23 AWG (0.6 mm) diameter (or smaller), copper conductor telecommunication cable with PE jacket.
- E. Max 3/C No. 15 AWG (1.5 mm) diameter (or smaller), copper conductor cable with PVC insulation and PVC jacket.

3. Firestop System

The Firestop System shall consist of the following:

- A. Packing material – Nom. 2-3/8 in. (60 mm) thick mineral wool board min. 9.3 pcf (150 kg/m³) firmly packed into the opening of the floor as a permanent form.
- B. Fill, Void or Cavity Material* – Min. 1/16 in. (2 mm) dry film thickness to be applied inside the aperture before installation and over the full surface of the mineral wool boards, and overlapping onto the floor by min. 3/4 in. (20 mm).
Flamro Brandschutz-Systeme GmbH – FLAMMOTECT-A
- C. Fill, Void or Cavity Material* – 2 lengths of 3 layers of 1/16 in (1.5 mm) by 5 in. (125 mm) wrap butt jointed centrally within the depth of the seal around the conduit to a total length of 10 in. (250 mm).
Flamro Brandschutz-Systeme GmbH – DG-CR 1.5
- D. 24 AWG Steel wire tied around 3C at nominally 1 in. (25 mm) and 2 in. (51 mm) from both faces of the seal.

*Indicates such products shall bear the UL or cUL Certification Mark for jurisdictions employing the UL or cUL Certification (such as Canada), respectively. Reprinted from Product iQ with permission from UL Solutions. ©2024 UL LLC.