

Through-penetration Firestop Systems

System No. F-A-5060

ANSI/UL1479 (ASTM E814)	CAN / ULC S115
F Rating – 3 Hr	F Rating – 3 Hr
T Rating – 3 Hr	FT Rating – 3 Hr
	FH Rating – 3 Hr
	FTH Rating – 3 Hr

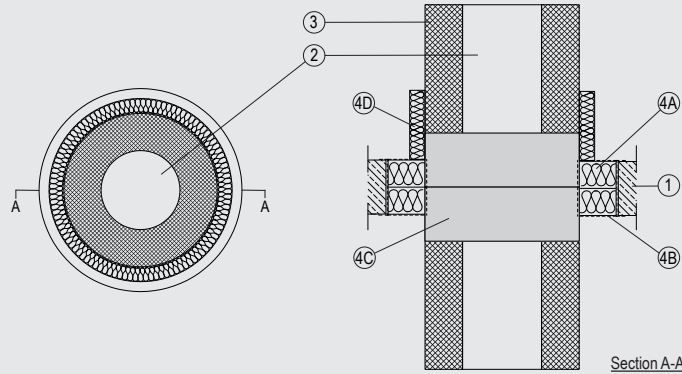

1. Floor Assembly

Min. 4-1/2 in. (115 mm) thick lightweight or normal weight (100-150 pcf or 1600 - 2400 kg/m³) concrete. Opening shall be circular or rectangular with max dimensions of 16-1/8 in. (409 mm).

2. Pipes/ Tubes

Single to be installed within the opening. The annular space between the pipes and the periphery of the opening to be 2 in (50 mm). Pipes to be rigidly supported on both sides of the floor assembly. The following penetrants may be used:

- A. Nominal 6-1/4 in (159 mm) diameter, Schedule M copper pipe for use in closed (process or supply) or vented (drain, waste or vent) piping systems.

3. Pipe Covering*

Nom 3 in. (75 mm) thick acrylonitrile butadiene/polyvinyl chloride (AB/PVC) flexible foam furnished in the form of tubing. The annular space between the insulated pipe or tubing and periphery of the opening shall be 2 in (50 mm). See Plastics+ (QMFZ2) category in the Plastics Recognized Component Directory for names of manufacturers. Any Recognized Component tube insulation material meeting the above specifications and having a UL 94 Flammability Classification of 95-5VA may be used.

4. Firestop System

The Firestop System shall consist of the following:

- A. Packing material – 2 layers of Nom. 2-3/8 in. (60 mm) thick mineral wool board min. 9.3 pcf (150 kg/m³) firmly packed into the opening of the floor as a permanent form.
- B. Min. 1/16 in. (2 mm) dry film thickness to be applied inside the aperture before installation and over the full surface of the mineral wool boards, and overlapping onto the floor by min. 3/4 in. (20 mm).

Flamro Brandschutz-Systeme GmbH – FLAMMOTECT-A

- C. Fill, Void or Cavity Material* – 2 lengths of 2 layer of 1/16 in (1.5 mm) by 5 in. (125 mm) wrap butt jointed centrally within the depth of the seal around pipe to a total length of 9-7/8 in. (250 mm).

Flamro Brandschutz-Systeme GmbH – DG-CR 1.5

- D. Duct Insulation – Nom. 1-1/4 in. (30 mm) thick stone wool mineral fibre 2.5-3.1 pcf (40-50 kg/m³) wrapped around duct for min. 20 in. (500 mm) on the top face.

*Indicates such products shall bear the UL or cUL Certification Mark for jurisdictions employing the UL or cUL Certification (such as Canada), respectively. Reprinted from Product iQ with permission from UL Solutions. ©2024 UL LLC.