

# Through-penetration Firestop Systems

## System No. F-A-1164

ANSI/UL1479 (ASTM E814)	CAN / ULC S115
F Rating – 3 Hr	F Rating – 3 Hr
T Rating – 2 Hr	FT Rating – 2 Hr
	FH Rating – 3 Hr
	FTH Rating – 2 Hr

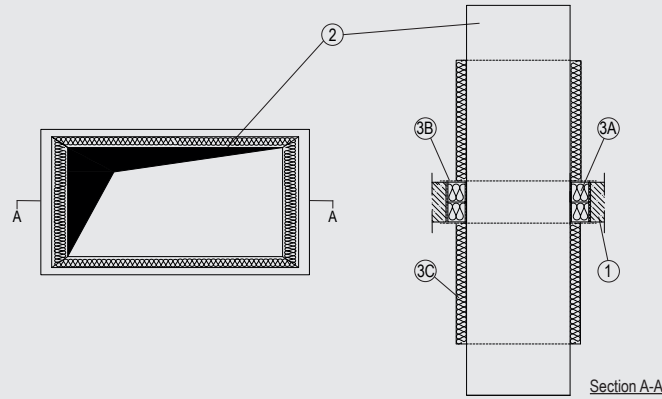

### 1. Floor Assembly

Min. 4-1/2 in. (115 mm) thick lightweight or normal weight (100-150 pcf or 1600 - 2400 kg/m<sup>3</sup>) concrete. Opening shall be rectangular with max dimensions of 11-3/4 in. (300 mm) by 7-7/8 (200 mm).

### 2. Duct

Single to be installed within the opening. The annular space between the duct and the periphery of the opening to be 2 in (50 mm). Ducts to be rigidly supported on both sides of the floor assembly. The following penetrants may be used:

- A. Max 7-7/8 in. (200 mm) by 4 in. (100 mm) galvanized steel duct.

### 3. Firestop System

The Firestop System shall consist of the following:

- A. Packing material – 2 layers of Nom. 2-3/8 in. (60 mm) thick mineral wool board min. 9.3 pcf (150 kg/m<sup>3</sup>) firmly packed into the opening of the floor as a permanent form.
- B. Fill, Void or Cavity Material\* – Min. 1/16 in. (2 mm) dry film thickness to be applied inside the aperture before installation and over the full surface of the mineral wool boards, and overlapping onto the wall by min. 3/4 in. (20 mm).  
**Flamro Brandschutz-Systeme GmbH – FLAMMOTECT-A**
- C. Duct Insulation – Nom. 1-1/4 in. (30 mm) thick 'Klimarock' mineral fibre lamella mat, min density 2.5 pcf (40 kg/m<sup>3</sup>), wrapped around duct for min. 10 in. (250 mm) on both faces.

\*Indicates such products shall bear the UL or cUL Certification Mark for jurisdictions employing the UL or cUL Certification (such as Canada), respectively. Reprinted from Product iQ with permission from UL Solutions. ©2024 UL LLC.