



ETA-Danmark A/S
Göteborg Plads 1
DK-2150 Nordhavn
Tel. +45 72 24 59 00
Fax +45 72 24 59 04
Internet www.etadanmark.dk

Authorised and notified according
to Article 29 of the Regulation (EU)
No 305/2011 of the European
Parliament and of the Council of 9
March 2011

MEMBER OF EOTA



European Technical Assessment ETA-18/0885 of 2024/06/11

General Part

Technical Assessment Body issuing the ETA and designated according to Article 29 of the Regulation (EU) No 305/2011: ETA-Danmark A/S

Trade name of the
construction product:

KSL-W Fire Protection Wrap

Product family to which the
above construction product
belongs:

Fire Stopping and Sealing with high performance
intumescent material used in penetration seals.

Manufacturer:

FLAMRO Brandschutz- Systeme GmbH
Am Sportplatz 2
DE-56291 Leiningen
Tel. + 49 6746 9410 - 0
Fax +49 6746 9410 - 10
Internet www.flamro.de

Manufacturing plant:

FLAMRO Brandschutz- Systeme GmbH
Manufacturing plant E

This European Technical
Assessment contains:

29 pages including 11 annexes which form an integral
part of the document

This European Technical
Assessment is issued in
accordance with Regulation
(EU) No 305/2011, on the
basis of:

EAD 350454-00-1104 – Fire Stopping and Fire Sealing
Products", "Penetration Seals".

This version replaces:

The ETA with the same number issued on 2018-10-18

Translations of this European Technical Assessment in other languages shall fully correspond to the original issued document and should be identified as such.

Communication of this European Technical Assessment, including transmission by electronic means, shall be in full (excepted the confidential Annex (es) referred to above). However, partial reproduction may be made, with the written consent of the issuing Technical Assessment Body. Any partial reproduction has to be identified as such

II SPECIFIC PART OF THE EUROPEAN TECHNICAL ASSESSMENT

1 Technical description of product

The KSL-W Fire Protection Wrap is an intumescent material with a width of 50 mm (or 100 mm) and a thickness of approx. 1,5 mm, which is wrapped in one or more layers around the pipe or the pipe insulation.

The KSL-W Fire Protection Wrap is installed in openings in fire classified walls or floors around pipes through walls made from concrete, aerated concrete, masonry, light weight partition structures, shaft wall constructions or concrete floors.

The construction product KSL-W is produced in rolls, cut at factory. It may also be delivered as intumescent strips, mats, cuts, and stamps (bands, blocks, pads) of dimension of request.

The intumescent product may be equipped on one side with a self-adhesive tape and/or on the other side with a lamination.

Detailed specifications for identification and performance criteria for fire safety regarding the construction product are given in the annexes of this ETA.

2 Specification of the intended use in accordance with the applicable European Assessment Document (hereinafter EAD)

The construction product KSL-W is assessed on the basis of EAD 350454-00-1104, as a fire stopping product, penetration seal.

The construction product KSL-W is intended for use as a component with a fire protection effect in building elements, assembled systems or constructions that are subject to requirements related to fire protection. Their reactive effect prevents heat transmission and fire spreading in the event of fire.

Within the scope of this ETA, the fire resistance was demonstrated for pipes made of combustible materials.

Pipe penetrations seals are used to seal off openings in fire resistant walls or floors, which are penetrated by pipes, and serves to preserve the walls or floors fire resistance in the area of the penetrations.

See annex 1 for a detailed specification of the intended use.

Detailed information and data on the verified penetration seals are given in Annexes 1 to 11.

The performances given in Section 3 exclusively relate to this penetration seals (e.g. with respect to the design and arrangement of the components of the penetration seals and the type and position of the services).

The verification and assessment methods on which this European Technical Assessment is based lead to the assumption of a working life of at least 10 years for The KSL-W Fire Protection Wrap.

The indications given on the working life cannot be interpreted as a guarantee given by the manufacturer, but are to be regarded only as a means for choosing the right product in relation to the expected economically reasonable working life of the works.

3 Performance of the product and references to the methods used for its assessment

Characteristic	Assessment of characteristic
3.2 Safety in case of fire (BWR 2)	
Reaction to fire	The product classified as Euroclass E in accordance with EN 13501-1 and delegated regulation 2016/364.
Resistance to fire	KSL-W Fire Protection Wrap is classified in accordance with EN 13501-2. See annex 1-11 for details.
3.3 Hygiene, health and the environment (BWR 3)	
Air permeability	No performance assessed
Water permeability	No performance assessed
Content, emission and / or release of dangerous substances	No performance assessed
3.4 Safety and accessibility in use (BWR 4)	
Mechanical resistance and stability	No performance assessed
Resistance to impact /movement	No performance assessed
Adhesion	No performance assessed
Durability	Use category X
3.5 Protection against noise (BWR 5)	
Airborne sound insulation	No performance assessed
3.6 Energy economy and heat retention (BW 6)	
Thermal properties	No performance assessed
Water vapour permeability	No performance assessed

*) See additional information in section 3.7 – 3.10.

3.7 Methods of verification

The assessment of the performance of “KSL-W” is in relation to the applicable BWR’s has been made in accordance with the European Assessment Document (EAD) no. EAD 350454-00-1104: Fire stopping and fire sealing products - Penetration seals.

3.8 General aspects

The verification of durability is part of testing the essential characteristics. The intumescent wrap “KSL-W” may be used in end-use applications according to the provisions for use category X (external use) without expecting significant changes of the characteristics relevant for fire protection. Products that meet requirements for type X, meet the requirement for all other types.

Products that meet the requirements for type Y₂ also meet the requirements for type Z₁ and Z₂

Additionally, the product was tested under specific application conditions according to EOTA TR 024, section 4.3:

- Exposure to a constant temperature of 80 °C for 40 days,
- Exposure to permanent wetness (water-immersion and permanent condensation) 4 weeks
- Exposure to solvents such as Butylacetat, Butanol, solvent naphtha and fuel oil
- Subsequent overpainting (tested with coatings on the basis of acryl dispersion, alkyd resin,
- polyurethane acryl and epoxide resin)
- Exposure to intimate contact with plastics (PVC, PE)
- Exposure to intimate contact with metals (steel, copper aluminum)

After the exposure according to EOTA TR 024 no essential changes of the intumescent properties, expansion rate and expansion pressure could be detected

It is assumed that:

- damages to the penetration seal are repaired accordingly,
- the installation of the penetration seal does not effect the stability of the adjacent building element – even in case of fire,
- the installations are fixed to the adjacent building element in accordance with the relevant regulations in such a way that, in case of fire, no additional mechanical load is imposed to the penetration seal.
- The support of the installations is maintained for the required period of the fire resistance and
- Pneumatic dispatch systems, compressed air systems, etc. are switched off by additional means in case of fire.

This European Technical Assessment does not address any risks associated with the emission of dangerous liquids or gases caused by failure of pipes in case of fire nor does it prove the prevention of the transmission of fire through heat transfer via the medium in the pipes.

The risk of downward spread of fire caused by burning material which drips through a pipe to floors below, is not considered in this European Technical Assessment (see EN 1366-3:2009, clause 1)

The durability assessment does not make account of the possible effect on the penetration seal of substances permeating through the pipe walls.

The assessment does not cover the avoidance or the destruction of the penetration seal or of the adjacent building elements by forces caused by temperatures changes in case of fire. This has to be considered when designing the piping system.

The European technical Assessment is issued for the product on the basis of agreed data /information, deposited with the ETA-Danmark. Changes to the product or production process, which could result in this deposited data / information being incorrect, should be notified to the ETA Danmark before the changes are introduced.

The ETA-Danmark will decide whether or not such changes affect the European Technical Assessment and if so whether further assessment or alterations to the European Technical Assessment, shall be necessary.

4 Assessment and verification of constancy of performance (hereinafter AVCP) system applied, with reference to its legal base

4.1 AVCP system

According to the decision 1999/454/EC of the European Commission, as amended by 2001/596/EC, the system(s) of assessment and verification of constancy of performance (see Annex V to Regulation (EU) No 305/2011) is 1.

5 Technical details necessary for the implementation of the AVCP system, as provided for in the applicable EAD

Technical details necessary for the implementation of the AVCP system are laid down in the control plan deposited at ETA-Danmark prior to CE marking the product

Issued in Copenhagen on 2024-06-11 by



Thomas Bruun
Managing Director, ETA-Danmark

Annex 1
Product details, definitions and specification of intended use

Product and performance of the KSL-W Fire Protection Wrap:

Property	Parameter	Method
Density	1,10 g/cm ³ - 1,68 g/cm ³	3.1.5 of EOTA TR No 024
Content of non-volatile components	No performance assessed	
Weight loss due to heating	No performance assessed	
Dimensions	0,8 mm to 3,6	3.1.2.1 of EOTA TR No 024
Expansion ratio	21,8 nominal thickness 1,0 mm max +/- 20[%] interval <u>17,4 – 26,2</u> 19,4 nominal thickness 3,0 mm max +/- 20[%] interval <u>15,5 – 23,3</u>	3.1.12 of EOTA TR No 024

KSL-W	Annex 1
Fire Stopping and Sealing with high performance intumescent material used in penetration seals	

Annex 2

Resistance to fire classification of KSL-W fire protection wrap mounted as single penetration seals

2.1 General information:

2.1.1. Wall/floor constructions

a. Flexible wall

The wall must have a minimum thickness of 100 mm and a metal profile frame lined on both faces with minimum 2 layers of 12,5 mm thick gypsum boards according to EN 520 type F.

In case that wooden stand walls are applied, a minimum distance of 100 mm must be kept from each of the wooden stands to the seal, and the cavity between the stands and the seal must be filled with at least 100 mm insulation material compliant to class A1 or A2 (in acc. with EN 13501-1).

b. Solid wall

Made of concrete or masonry with a thickness of ≥ 100 mm. (density 650 ± 200 kg/m³)

c. Rigid floor

Made of concrete or aerated concrete with a thickness of ≥ 150 mm (density 650 ± 200 kg/m³).

d. Shaft wall

In stud design with metal substructure and one-sided cladding of at least 2 layers made of building slabs with a thickness of 20 mm.

2.1.2. Annular gap

a. filling material

Ablative or intumescent filler or non-combustible material (class A1 or A2-s1, d0 according to EN 13501-1) as e.g. concrete, cementitious or gypsum mortar.

b. Filler depth each side ≥ 25 mm (≥ 20 mm shaft wall)

c. gap width ≤ 50 mm

d. Back-up filling material (optional) Loose stone wool

2.1.3 Working space

Working space between services ≥ 50 mm,

KSL-W	Annex 2
Fire Stopping and Sealing with high performance intumescent material used in penetration seals	

Annex 3

Description of the installations for the confirmation of fire resistance in at least 100 mm walls

Installation in flexible walls or in solid walls with or without PE- Sound insulation

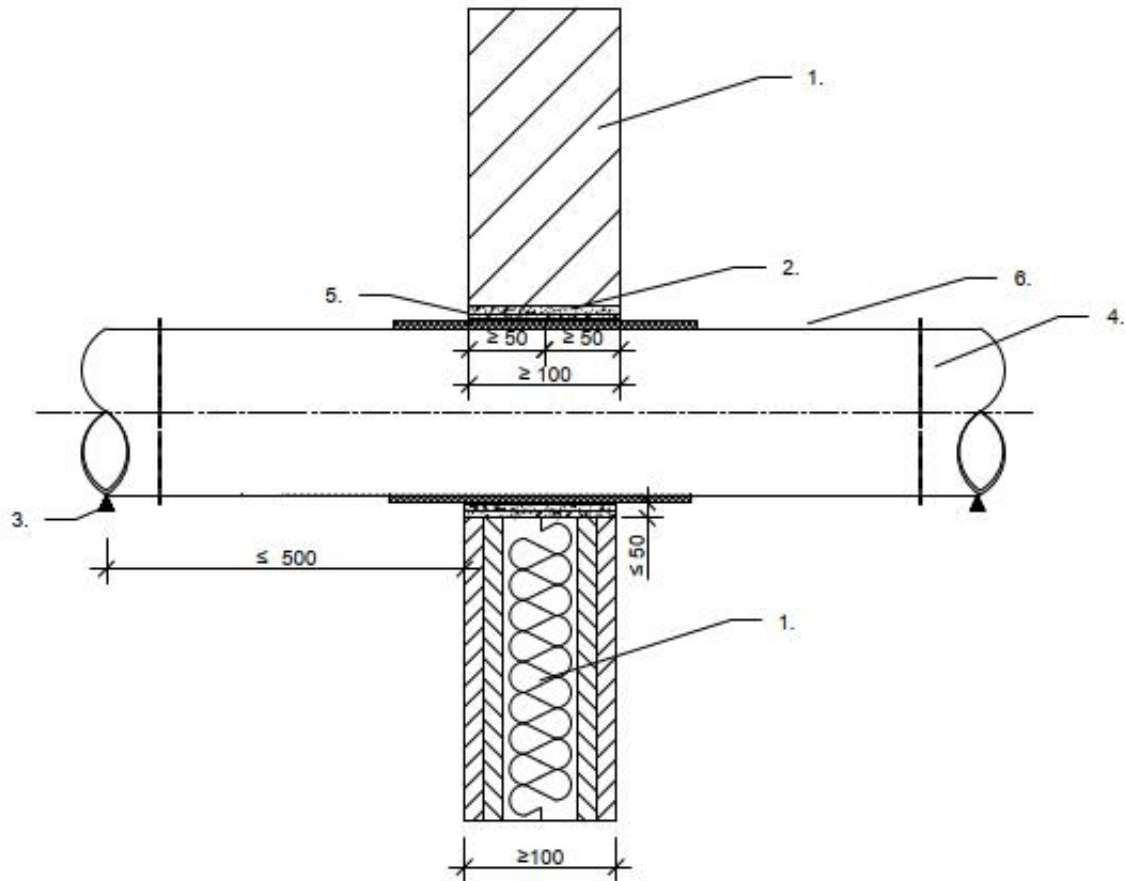

1. Rigid wall / Flexible wall ≥ 100 mm
2. Annular Gap
 ≤ 50 mm ablative or intumescent filler or non-combustible material
 (class A1 or A2-s1,d0 according to EN 13501-1)
 as e.g. concrete, cementitious or gypsum mortar
3. First support
4. Plastic pipes or multilayer pipes
5. Intumescent wrap
 (in different layers)
6. PE-Soundinsulation

KSL-W Fire Stopping and Sealing with high performance intumescent material used in penetration seals	Annex 3
--	---------

Annex 3**Description of the installations for the confirmation of fire resistance in at least 100 mm walls**

Regulated pipes with/without 5 mm PE Soundinsulation			
Service	Pipe wall thickness	Measures Qty + No. of layers	Fire resistance class
PVC-U, PVC-C			
Ø 32 – 50 mm	1,8 - 5,6	2 x 2 layers	EI 120 U/U
Ø 63 – 110 mm	1,8 - 12,3	2 x 4 layers	EI 120 U/U
PE-HD, ABS, SAN+PVC			
Ø 32 – 50 mm	1,8- 4,6	2 x 2 layers	EI 120 U/U
Ø 63 – 110 mm	1,8 - 10,0	2 x 4 layers	EI 120 U/U
PP			
Ø 32 – 50 mm	1,8 - 4,6	2 x 2 layers	EI 120 U/U
Ø 63 – 110 mm	1,8 - 10,0	2 x 4 layers	EI 120 U/U

KSL-W	Annex 3.1
Fire Stopping and Sealing with high performance intumescent material used in penetration seals	

Non-regulated pipes with/without 5 mm PE Soundinsulation			
Service	Pipe wall thickness	Measures Qty + No. of layers	Fire resistance class
Geberit Silent PP			
Ø ≤ 50 mm	2,0 - 3,6	2 x 2 layers	EI 120 U/U
Ø ≤ 110 mm		2 x 4 layers	EI 120 U/U
Geberit Silent Pro			
Ø ≤ 75 mm	3,8 - 4,5	2 x 3 layers	EI 120 U/U
Ø ≤ 110 mm		2 x 4 layers	EI 120 U/U
Kekelit Phon EX AS			
Ø ≤ 56 mm	4,0	2 x 2 layers	EI 120 U/U
Ø ≤ 110 mm	5,3	2 x 4 layers	EI 120 U/U
Pipelife Master 3			
Ø ≤ 50 mm	1,8 - 2,0	2 x 2 layers	EI 120 U/U
Ø ≤ 110 mm	2,1 - 3,0	2 x 4 layers	EI 120 U/U
POLO-KAL NG / POLO KAL XS			
Ø ≤ 50 mm	1,8 - 2,0	2 x 2 layers	EI 120 U/U
Ø ≤ 110 mm	2,6 - 3,4	2 x 4 layers	EI 120 U/U
Rehau Raupiano light			
Ø ≤ 50 mm	1,8 - 2,7	2 x 2 layers	EI 120 U/U
Ø ≤ 110 mm		2 x 4 layers	EI 120 U/U
Rehau RAUSILENTO			
Ø ≤ 50 mm	1,8 - 2,7	2 x 2 layers	EI 120 U/U
Ø ≤ 110 mm		2 x 4 layers	EI 120 U/U
Conel DRAIN			
Ø ≤ 50 mm	1,8 - 2,7	2 x 2 layers	EI 120 U/U
Ø ≤ 110 mm		2 x 4 layers	EI 120 U/U
Geberit Silent dB20			
Ø ≤ 56 mm	3,2	2 x 2 layers	EI 120 U/U
Ø ≤ 110 mm	5,5 - 6,0	2 x 4 layers	EI 120 U/U
Wavin SiTech+			
Ø ≤ 50 mm	2,0 - 2,1	2 x 2 layers	EI 120 U/U
Ø ≤ 110 mm	2,6 - 3,4	2 x 4 layers	EI 120 U/U
Rehau Raupiano plus			
Ø ≤ 50 mm	1,8	2 x 2 layers	EI 120 U/U
Ø ≤ 110 mm	1,9 - 2,7	2 x 4 layers	EI 120 U/U
Silenta Premium			
Ø ≤ 58 mm	4,1	2 x 2 layers	EI 120 U/U
Ø ≤ 110 mm	4,6 - 5,3	2 x 4 layers	EI 120 U/U

KSL-W	Annex 3.2
Fire Stopping and Sealing with high performance intumescent material used in penetration seals	

Annex 4

Description of the installations for the confirmation of fire resistance in at least 100 mm walls

Installation in flexible wall or in solid walls with FEF- insulation

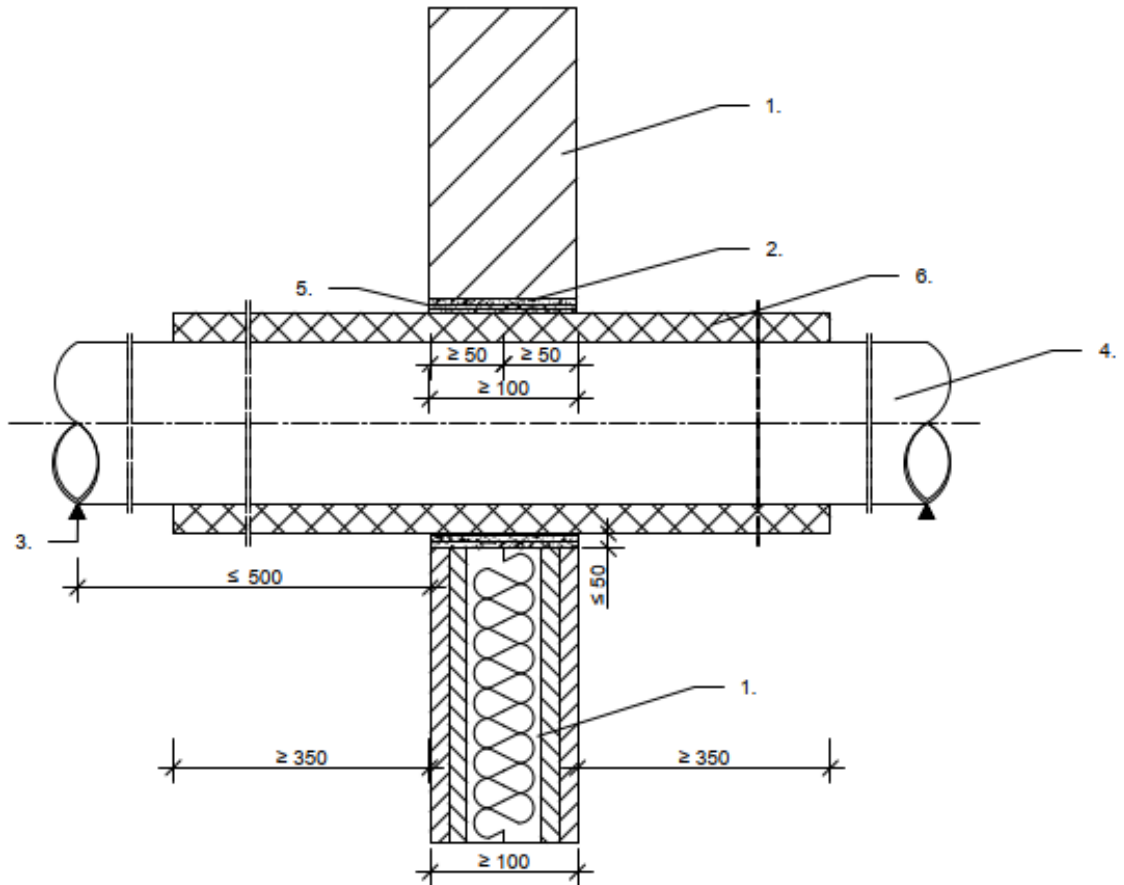

1. Rigid wall / Flexible wall ≥ 100 mm
2. Annular Gap
 ≤ 50 mm ablative or intumescent filler or non-combustible material
 (class A1 or A2-s1,d0 according to EN 13501-1)
 as e.g. concrete, cementitious or gypsum mortar
3. First support
4. Plastic pipes or multilayer pipes
5. Intumescent wrap
 (in different layers)
6. FEF - insulation
 (acc. to EN 14304)

KSL-W	Annex 4
Fire Stopping and Sealing with high performance intumescent material used in penetration seals	

Annex 4

Description of the installations for the confirmation of fire resistance in at least 100 mm walls

Multi-layer composite pipes with FEF Insulation					
Service	Pipe wall thickness	Insulation type	Insulation thickness	Measures Qty + No. of layers	Fire resistance class
Geberit Mepla					
Ø 16 mm	2,25 - 3,0	FEF acc. EN 14304	8.0 – 32 mm	2 x 1-layer	EI 120 U/C
Ø 20 mm			EI 120 U/C		
Ø 26 mm			8.5 – 35 mm		EI 120 U/C
Ø 32 mm			9.0 – 35 mm		EI 120 U/C
Ø 40 mm	3,5 - 4,7	FEF acc. EN 14304	9.0 – 35 mm	2 x 2-layers	EI 120 U/C
Ø 50 mm			EI 120 U/C		
Ø 63 mm			9.0 – 39 mm		EI 120 U/C
Ø 75 mm			9.5 mm > 9.5 – 40.5 mm		EI 90 U/C EI 120 U/C
Rehau Rautitan stabil					
Ø 16 mm	2,6 - 4,7	FEF acc. EN 14304	8.0 – 32 mm	2 x 1-layer	EI 120 U/C
Ø 20 mm			EI 120 U/C		
Ø 25 mm			8.5 – 35 mm		EI 120 U/C
Ø 32 mm			9.0 – 35 mm		EI 120 U/C
Ø 40 mm	6,0	FEF acc. EN 14304	9.0 – 35 mm	2 x 2-layers	EI 120 U/C
Kekelit Kelox					
Ø 16 mm	2,0 - 3,0	FEF acc. EN 14304	8.0 – 32 mm	2 x 1-layer	EI 120 U/C
Ø 18 mm					EI 120 U/C
Ø 20 mm					EI 120 U/C
Ø 25 mm			8.5 – 35 mm		EI 120 U/C
Ø 32 mm			9.0 – 35 mm		EI 120 U/C
Ø 40 mm	4,0 - 7,5	FEF acc. EN 14304	9.0 – 35 mm	2 x 2-layers	EI 120 U/C
Ø 50 mm			EI 120 U/C		
Ø 63 mm			9.0 – 39 mm		EI 120 U/C
Ø 75 mm			9.5 – 40.5 mm		EI 120 U/C
HENCO					
Ø 20 mm	2,0 - 3,0	FEF acc. EN 14304	8.0 – 32 mm	2 x 1-layer	EI 120 U/C
Ø 32 mm					EI 120 U/C
Geberit FlowFit					
Ø 16 - 32 mm	2,0 - 2,8	FEF acc. EN 14304	8.5 – 33.5 mm	2 x 1-layer	EI 90 U/C

KSL-W

Fire Stopping and Sealing with high performance intumescent material used in penetration seals

Annex 4.1

Annex 5

Description of the installations for the confirmation of fire resistance in at least 100 mm walls

Installation in flexible walls or in solid walls with PEF- insulation

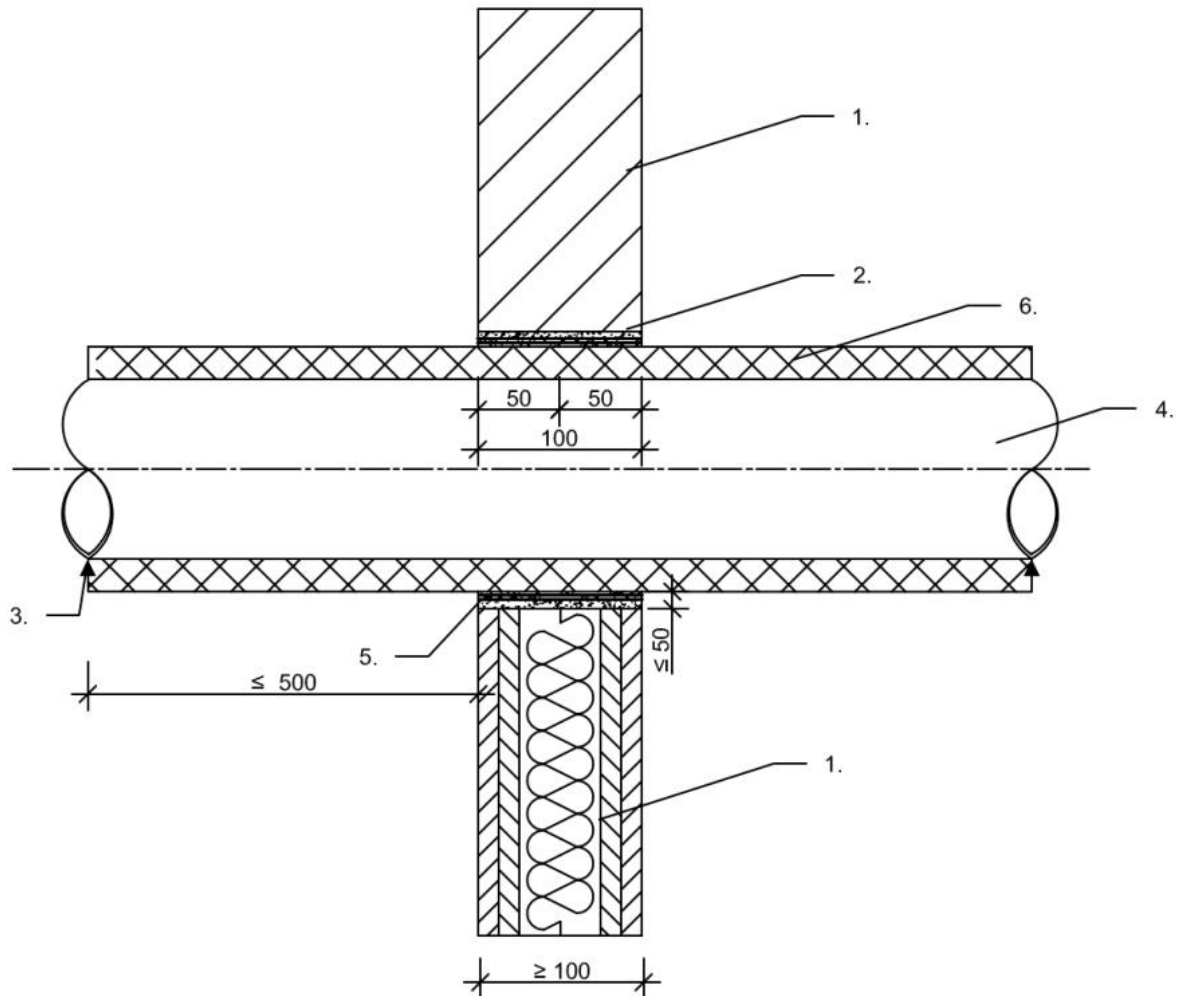

1. Rigid wall / Flexible wall ≥ 100 mm
2. Annular Gap
 ≤ 50 mm ablative or intumescent filler or non-combustible material
 (class A1 or A2-sl,d0 according to EN 13501-1)
 as e.g. concrete, cementitious or gypsum mortar
3. First support
4. Plastic pipes or multilayer pipes
5. Intumescent wrap
 (in different layers)
6. PEF - insulation
 (acc. to EN 14313)

KSL-W

Fire Stopping and Sealing with high performance intumescent material used in penetration seals

Annex 5

Annex 5

Description of the installations for the confirmation of fire resistance in at least 100 mm walls

Multi-layer composite pipes with PEF Insulation					
Service	Pipe wall thickness	Insulation type	Insulation thickness	Measures Qty + No. of layers	Fire resistance class
Geberit Mepla					
Ø 16 mm	2,25 - 3,0	PEF acc. EN 14313	6 – 13 mm	2 x 1-layer	EI 120 U/C
Ø 20 mm					EI 120 U/C
Ø 26 mm					EI 120 U/C
Ø 32 mm					EI 120 U/C
Rehau Rautitan stabil					
Ø 16 mm	2,6 - 4,7	PEF acc. EN 14313	4 – 26 mm	2 x 1-layer	EI 120 U/C
Ø 20 mm					EI 120 U/C
Ø 25 mm					EI 120 U/C
Ø 32 mm					EI 120 U/C
Kekelit Kelox					
Ø 18 mm	2,0 - 3,0	PEF acc. EN 14313	4 – 13 mm	2 x 1-layer	EI 120 U/C
Ø 20 mm					EI 120 U/C
Ø 25 mm					EI 120 U/C
Ø 32 mm					EI 120 U/C
HENCO					
Ø 20 mm	2,0 - 3,0	PEF acc. EN 14313	6 – 13 mm	2 x 1-layer	EI 120 U/C
Ø 32 mm					EI 120 U/C
Geberit FlowFit					
Ø 16 mm	2,0 - 2,5	PEF acc. EN 14313	13 – 26 mm	2 x 1-layer	EI 90 U/C
Ø 20 - 25 mm			26 mm		EI 90 U/C

KSL-W	Annex 5.1
Fire Stopping and Sealing with high performance intumescent material used in penetration seals	

Annex 6

Description of the installations for the confirmation of fire resistance in at least 150 mm floors

installation in concrete floors with or without PE- Sound insulation

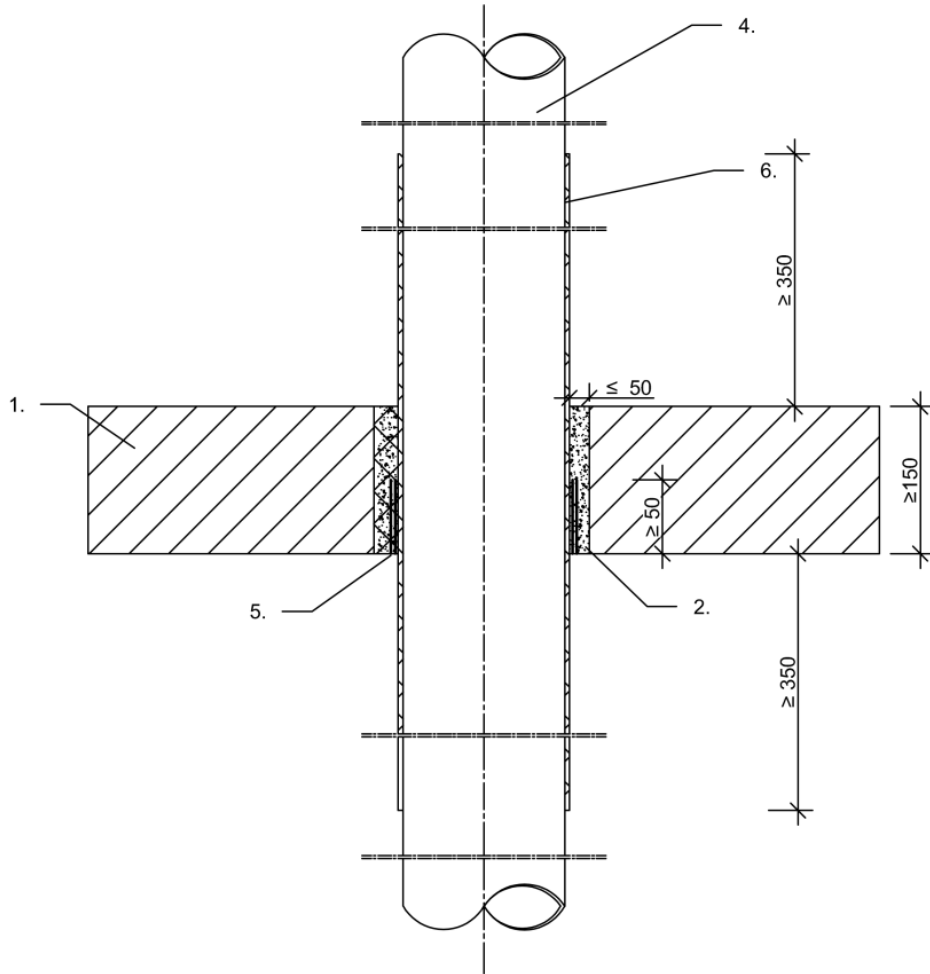

1. Rigid floor
2. Annular gap
 ≤ 50 mm ablative or intumescent filler or non-combustible material
(class A1 or A2-sl, d0 according to EN 13501-1
as e.g. concrete, cementitious or gypsum mortar
4. Plastic pipes or multilayer pipes
5. Intumescent wrap
(in different layers)
6. PE sound insulation

KSL-W

Fire Stopping and Sealing with high performance intumescent material used in penetration seals

Annex 6

Annex 6**Description of the installations for the confirmation of fire resistance in at least 150 mm floors**

Regulated pipes with/without 5 mm PE Soundinsulation			
Service	Pipe wall thickness	Measures Qty + No. of layers	Fire resistance class
PVC-U, PVC-C			
Ø 32 – 50 mm	1,8 - 5,6	1 x 2 layers	EI 120 U/U
Ø 63 – 110 mm	1,8 - 12,3	1 x 4 layers	EI 90 U/U
PE-HD, ABS, SAN+PVC			
Ø 32 – 50 mm	1,8 - 4,6	1 x 2 layers	EI 180 U/U
Ø 63 – 110 mm	1,8 - 10,0	1 x 4 layers	EI 180 U/U
PP			
Ø 32 – 50 mm	1,8 - 4,6	1 x 2 layers	EI 120 U/U
Ø 63 – 110 mm	2,7 - 10,0	1 x 4 layers	EI 120 U/U

KSL-W	Annex 6.1
Fire Stopping and Sealing with high performance intumescent material used in penetration seals	

Description of the installations for the confirmation of fire resistance in at least 150 mm floors

Non-regulated pipes with/without 5 mm PE Soundinsulation			
Service	Pipe wall thickness	Measures Qty + No. of layers	Fire resistance class
Geberit Silent PP			
Ø ≤ 50 mm	2,0	1 x 2 layers	EI 120 U/U
Ø ≤ 110 mm	3,6	1 x 4 layers	EI 180 U/U
Geberit Silent Pro			
Ø ≤ 75 mm	3,0 - 3,8	1 x 3 layers	EI 180 U/U
Ø ≤ 110 mm	4,3 - 4,5	1 x 4 layers	EI 180 U/U
Kekelit Phon EX AS			
Ø ≤ 56 mm	4,0	1 x 2 layers	EI 180 U/U
Ø ≤ 110 mm	5,3	1 x 4 layers	EI 180 U/U
Pipelife Master 3			
Ø ≤ 50 mm	1,8 - 2,0	1 x 2 layers	EI 90 U/U
Ø ≤ 110 mm	2,1 - 3,0	1 x 4 layers	EI 180 U/U
POLO-KAL NG / POLO KAL XS			
Ø ≤ 50 mm	1,8 - 2,0	1 x 2 layers	EI 180 U/U
Ø ≤ 110 mm	2,1 - 3,0	1 x 4 layers	EI 180 U/U
Rehau Raupiano light			
Ø ≤ 50 mm	1,8	1 x 2 layers	EI 180 U/U
Ø ≤ 110 mm	1,9 - 2,7	1 x 4 layers	EI 180 U/U
Rehau RAUSILENTO			
Ø ≤ 50 mm	1,8	1 x 2 layers	EI 180 U/U
Ø ≤ 110 mm	1,9 - 2,7	1 x 4 layers	EI 180 U/U
Conel DRAIN			
Ø ≤ 50 mm	1,8	1 x 2 layers	EI 180 U/U
Ø ≤ 110 mm	1,9 - 2,7	1 x 4 layers	EI 180 U/U
Geberit Silent dB20			
Ø ≤ 56 mm	1,8	1 x 2 layers	EI 180 U/U
Ø ≤ 110 mm	1,9 - 2,7	1 x 4 layers	EI 180 U/U
Wavin SiTech+			
Ø ≤ 50 mm	2,0- 2,1	1 x 2 layers	EI 180 U/U
Ø ≤ 110 mm	2,6 - 3,4	1 x 4 layers	EI 120 U/U
Rehau Raupiano plus			
Ø ≤ 50 mm	1,8	1 x 2 layers	EI 60 U/U
Ø ≤ 110 mm	1,9 - 2,7	1 x 4 layers	EI 180 U/U
Silenta Premium			
Ø ≤ 58 mm	4,1	1 x 2 layers	EI 90 U/U
Ø ≤ 110 mm	4,6 - 5,3	1 x 4 layers	EI 180 U/U

KSL-W

Fire Stopping and Sealing with high performance intumescent material used in penetration seals

Annex 6.2

Annex 7

Description of the installations for the confirmation of fire resistance in at least 150 mm floors

installation in concrete floors with FEF- insulation

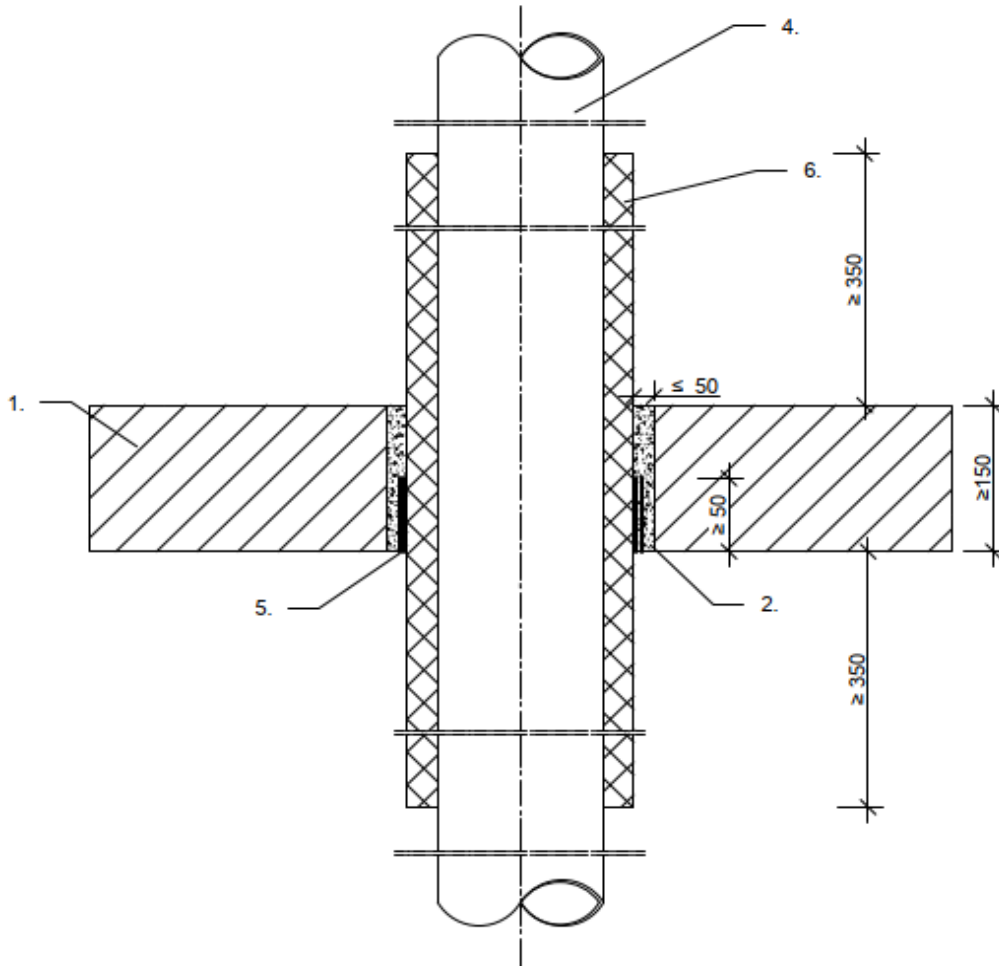

1. Rigid floor ≥ 150 mm
2. Annular gap
 ≤ 50 mm ablative or intumescent filler or non-combustible material
(class A1 or A2-sl,d0 according to EN 13501-1
as e.g. concrete, cementitious or gypsum mortar)
4. Plastic pipes or multilayer pipes
5. Intumescent wrap
(in different layers)
6. FEF - insulation
(acc. to EN 14304)

KSL-W	Annex 7
Fire Stopping and Sealing with high performance intumescent material used in penetration seals	

Description of the installations for the confirmation of fire resistance in at least 150 mm floors

Non-regulated pipes with FEF Insulation					
Service	Pipe wall thickness	Insulation type	Insulation thickness	Measures Qty + No. of layers	Fire resistance class
Geberit Silent PP					
Ø ≤ 50 mm	2,0	FEF acc. EN 14304	17.0 mm	1 x 2 layers	EI 180 U/U
Ø > 100 - ≤ 125 mm	3,6 - 4,2		18.5 mm	1 x 5 layers	EI 120 U/U
Geberit Silent Pro					
Ø ≤ 50 mm	3,0	FEF acc. EN 14304	17.0 mm	1 x 2 layers	EI 180 U/U
Ø > 75 - ≤ 110 mm			3,8 - 4,5	18.0 mm	1 x 4 layers
Geberit Silent dB20					
Ø ≤ 56 mm	3,2	FEF acc. EN 14304	17.0 mm	1 x 2 layers	EI 180 U/U
Ø > 56 - ≤ 110 mm	3,2 - 6,0		18.0 mm	1 x 4 layers	EI 90 U/U
Ø > 110 - ≤ 135 mm	6,0		18.5 mm	1 x 5 layers	EI 180 U/U
Ø > 135 - ≤ 160 mm	6,0 - 7,0		19.0 mm	1 x 6 layers	EI 180 U/U
Pipelife Master 3					
Ø ≤ 50 mm	1,8 - 2,0	FEF acc. EN 14304	17.0 mm	1 x 2 layers	EI 180 U/U
Ø > 50 - ≤ 110 mm	2,0 - 3,0		18.0 mm	1 x 4 layers	EI 120 U/U
POLO-KAL NG / POLO KAL XS					
Ø ≤ 50 mm	1,8 - 2,0	FEF acc. EN 14304	17.0 mm	1 x 2 layers	EI 180 U/U
Ø > 50 - ≤ 110 mm	2,0 - 3,4		18.0 mm	1 x 4 layers	EI 180 U/U
Rehau Raupiano light					
Ø ≤ 50 mm	1,8	FEF acc. EN 14304	17.0 mm	1 x 2 layers	EI 180 U/U
Ø > 50 - ≤ 110 mm	1,8 - 2,7		18.0 mm	1 x 4 layers	EI 180 U/U
Ø > 110 - ≤ 125 mm	2,7 - 3,1		18.5 mm	1 x 5 layers	EI 180 U/U
Ø > 125 - ≤ 160 mm	3,1 - 3,9		19.0 mm	1 x 6 layers	EI 90 U/U
Rehau Raupiano Plus					
Ø ≤ 50 mm	1,8	FEF acc. EN 14304	17.0 mm	1 x 2 layers	EI 180 U/U
Conel DRAIN					
Ø ≤ 50 mm	1,8	FEF acc. EN 14304	17.0 mm	1 x 2 layers	EI 180 U/U
Wavin SiTech					
Ø ≤ 50 mm	2,0 - 2,1	FEF acc. EN 14304	17.0 mm	1 x 2 layers	EI 180 U/U
Ø > 50 - ≤ 110 mm	2,6 - 3,4		18.0 mm	1 x 4 layers	EI 180 U/U
Wavin SiTech+					
Ø ≤ 50 mm	2,0 - 2,1	FEF acc. EN 14304	17.0 mm	1 x 2 layers	EI 180 U/U
Ø > 50 - ≤ 110 mm	2,6 - 3,4		18.0 mm	1 x 4 layers	EI 180 U/U

KSL-W

Fire Stopping and Sealing with high performance intumescent material used in penetration seals

Annex 7.1

Annex 7

Description of the installations for the confirmation of fire resistance in at least 150 mm floors

Service	Pipe wall thickness	Insulation type	Insulation thickness	Measures Qty + No. of layers	Fire resistance class
Wavin AS					
$\varnothing \leq 58$ mm	4,0	FEF acc. EN 14304	17.0 mm	1 x 2 layers	EI 180 U/U
$\varnothing > 58 - \leq 110$ mm	5,3		18.0 mm	1 x 4 layers	EI 180 U/U
Silenta Premium					
$\varnothing \leq 58$ mm	4,1	FEF acc. EN 14304	17.0 mm	1 x 2 layers	EI 180 U/U
$\varnothing > 58 - \leq 110$ mm	4,1 - 5,3		18.0 mm	1 x 4 layers	EI 180 U/U
$\varnothing > 110 - \leq 135$ mm	5,3		18.5 mm	1 x 5 layers	EI 120 U/U
Ostendorf Skolan DB					
$\varnothing \leq 58$ mm	4,0	FEF acc. EN 14304	17.0 mm	1 x 2 layers	EI 180 U/U
$\varnothing > 58 - \leq 110$ mm	4,0 - 5,3		18.0 mm	1 x 4 layers	EI 60 U/U
$\varnothing > 110 - \leq 135$ mm	5,3		18.5 mm	1 x 5 layers	EI 120 U/U

KSL-W

Fire Stopping and Sealing with high performance intumescent material used in penetration seals

Annex 7.2

Description of the installations for the confirmation of fire resistance in at least 150 mm floors

Multi-layer composite pipes with FEF Insulation						
Service	Pipe wall thickness	Insulation type	Insulation thickness	Measures Qty + No. of layers	Fire resistance class	
Geberit Mepla						
Ø 16 mm	2,25 - 4,7	FEF acc. EN 14304	8.0 – 32 mm	1 x 1-layer	EI 180 U/C	
Ø 20 mm			8.0 mm		EI 120 U/C	
Ø 26 mm			> 8.0 – 32 mm		EI 180 U/C	
Ø 32 mm			8.5 – 35 mm		EI 180 U/C	
Ø 32 mm			9.0 mm		EI 180 U/C	
Ø 40 mm		FEF acc. EN 14304	> 9.0 – 35 mm	1 x 2-layers	EI 120 U/C	
Ø 40 mm			9.0 mm		EI 180 U/C	
Ø 50 mm			> 9.0 – 35 mm		EI 120 U/C	
Ø 50 mm			9.0 – 37.5 mm		EI 120 U/C	
Ø 63 mm			9.0 mm		EI 180 U/C	
Ø 63 mm	> 9.0 – 39 mm	EI 120 U/C				
Ø 75 mm		9.5 mm	EI 90 U/C			
Ø 75 mm		> 9.0 – 40.5 mm	EI 120 U/C			
Rehau Rautitan stabil						
Ø 16 mm	2,6 - 4,7	FEF acc. EN 14304	8.0 – 32 mm	1 x 1-layer	EI 180 U/C	
Ø 20 mm			EI 180 U/C			
Ø 25 mm			8.5 – 35 mm		EI 180 U/C	
Ø 32 mm			9.0 mm		EI 120 U/C	
Ø 32 mm	6	FEF acc. EN 14304	> 9.0 – 35 mm	1 x 2-layers	EI 180 U/C	
Ø 40 mm			9.0 – 35 mm		EI 180 U/C	
Kekelit Kelox						
Ø 16 mm	2,0 - 4,0	FEF acc. EN 14304	8.0 – 32 mm	1 x 1-layer	EI 180 U/C	
Ø 18 mm					EI 180 U/C	
Ø 20 mm					EI 180 U/C	
Ø 25 mm					8.5 – 35 mm	EI 180 U/C
Ø 32 mm					9.0 – 35 mm	EI 180 U/C
Ø 40 mm	4,0 - 7,5	FEF acc. EN 14304	9.0 – 35 mm	1 x 2-layers	EI 180 U/C	
Ø 50 mm					EI 180 U/C	
Ø 63 mm					9.0 – 39 mm	EI 180 U/C
Ø 75 mm					9.5 – 40.5 mm	EI 180 U/C
Geberit FlowFit						
Ø 16 - 32 mm	2,0 - 4,7	FEF acc. EN 14304	8.5 – 35 mm	1 x 1-layer	EI 90 U/C	
Ø 40 - 75 mm			20.5 – 40.5 mm	1 x 2-layers	EI 90 U/C	

KSL-W

Fire Stopping and Sealing with high performance intumescent material used in penetration seals

Annex 7.3

Annex 8

Description of the installations for the confirmation of fire resistance in at least 150 mm floors

installation in concrete floors with PEF- insulation

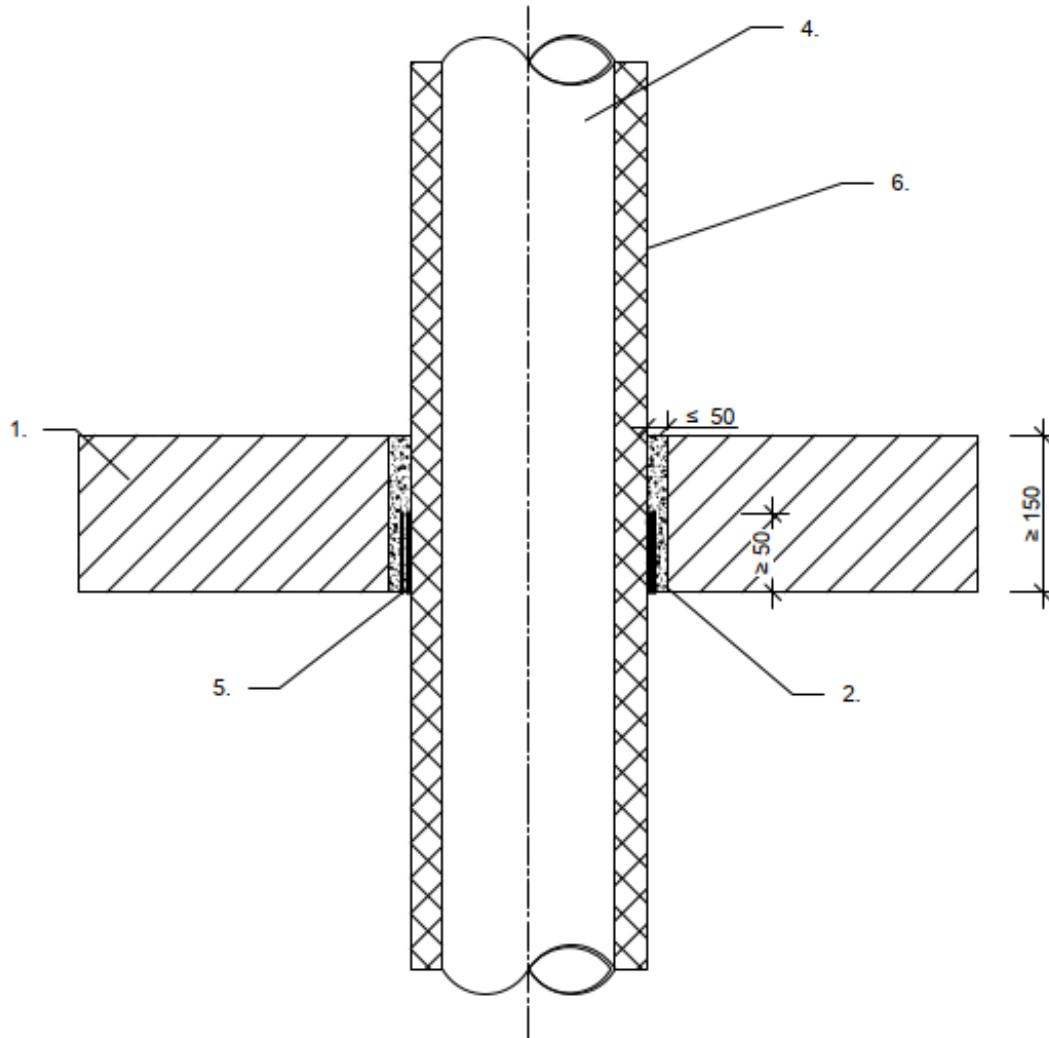

1. Rigid floor ≥ 150 mm
2. Annular gap
 ≤ 50 mm ablative or intumescent filler or non-combustible material
(class A1 or A2-s1,d0 according to EN 13501-1)
as e.g. concrete, cementitious or gypsum mortar
4. Plastic pipes or multilayer pipes
5. Intumescent wrap
(in different layers)
6. PEF - insulation
(acc. to EN 14313)

KSL-W

Fire Stopping and Sealing with high performance intumescent material used in penetration seals

Annex 8

Annex 8

Description of the installations for the confirmation of fire resistance in at least 150 mm floors

Multi-layer composite pipes with PEF Insulation					
Service	Pipe wall thickness	Insulation type	Insulation thickness	Measures Qty + No. of layers	Fire resistance class
Geberit Mepla					
Ø 16 mm	2,25 - 3,0	PEF acc. EN 14313	6 – 13 mm	1 x 1-layer	EI 120 U/C
Ø 20 mm					EI 120 U/C
Ø 26 mm					EI 120 U/C
Ø 32 mm					EI 120 U/C
Rehau Rautitan stabil					
Ø 16 mm	2,6 - 4,7	PEF acc. EN 14313	4 – 26 mm	1 x 1-layer	EI 120 U/C
Ø 20 mm			26 mm		EI 120 U/C
Ø 25 mm					EI 120 U/C
Ø 32 mm			EI 120 U/C		
Kekelit Kelox					
Ø 18 mm	2,0 - 3,0	PEF acc. EN 14313	4 – 13 mm	1 x 1-layer	EI 120 U/C
Ø 20 mm					EI 120 U/C
Ø 25 mm					EI 120 U/C
Ø 32 mm					EI 120 U/C
HENCO					
Ø 20 mm	2,0 - 3,0	PEF acc. EN 14313	6 – 13 mm	1 x 1-layer	EI 120 U/C
Ø 32 mm			13 mm		EI 120 U/C
Geberit FlowFit					
Ø 16 - 25 mm	2,0 - 2,5	PEF acc. EN 14313	6 – 26 mm	1 x 1-layer	EI 90 U/C

KSL-W	Annex 8.1
Fire Stopping and Sealing with high performance intumescent material used in penetration seals	

Annex 9

Detailed information for the confirmation of fire resistance in shaft walls

Installation in shaft walls

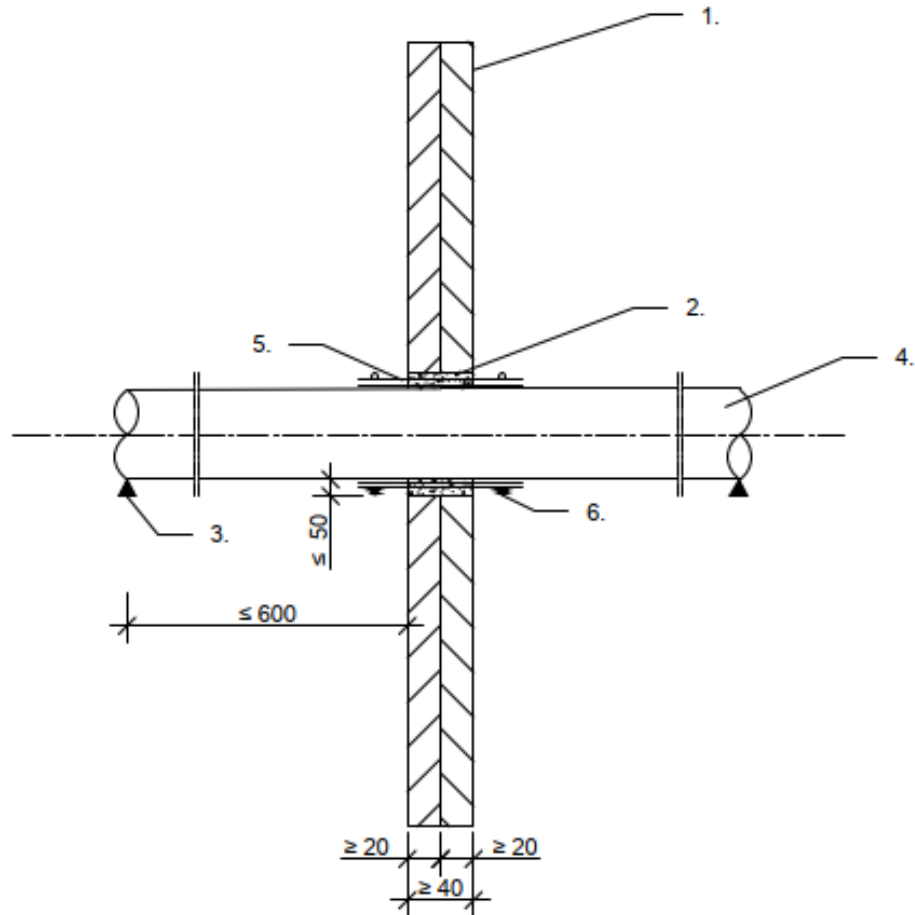

1. Shaft wall ≥ 40 mm
2. Annular Gap
 ≤ 50 mm ablative or intumescent filler or non-combustible material
 (class A1 or A2-sl,d0 according to EN 13501-1)
 as e.g. concrete, cementitious or gypsum mortar
3. First support
4. Plastic pipe or multilayer pipes
5. Intumescent wrap
 (in different layers)
6. Tensioning straps

KSL-W

Fire Stopping and Sealing with high performance intumescent material used in penetration seals

Annex 9

Annex 9**Detailed information for the confirmation of fire resistance in shaft walls**

Non regulated pipes			
Service	Pipe wall thickness	Measures Qty + No. of layers	Fire resistance class
Pipelife Master 3+			
$\varnothing \leq 50$ mm	2,0 mm	1 x 3 layers 100 mm width	EI 90 U/U
$\varnothing \leq 110$ mm	3,6 mm	1 x 6 layers 100 mm width	EI 90 U/U

KSL-W

Fire Stopping and Sealing with high performance intumescent material used in penetration seals

Annex 9.1

Annex 10

Detailed information for the confirmation of fire resistance in shaft walls

Installation in shaft walls with mineral wool board

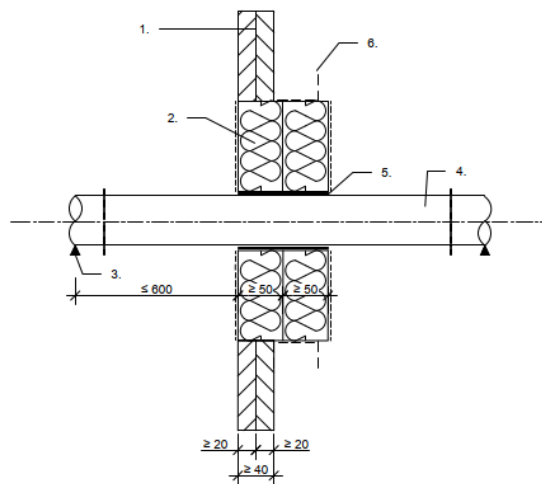
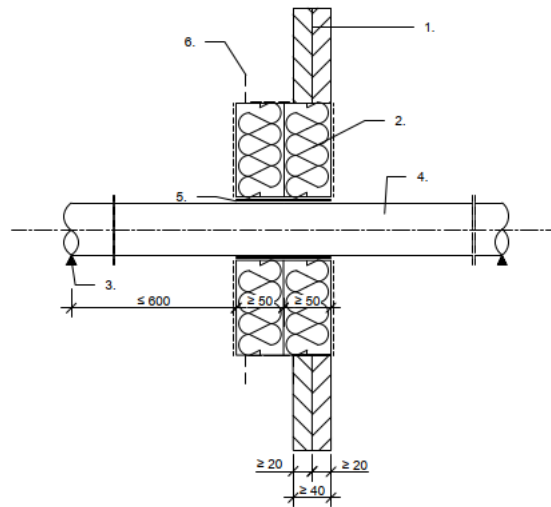

1. Shaft wall ≥ 40 mm
2. Mineral wool board with ablative coating
3. First support
4. Plastic pipe or multilayer pipe
5. Intumescent wrap (in different layers)
6. U-Profile

KSL-W	Annex 10
Fire Stopping and Sealing with high performance intumescent material used in penetration seals	

Annex 10

Detailed information for the confirmation of fire resistance in shaft walls

Regulated pipes			
Service	Pipe wall thickness	Measures Qty + No. of layers	Fire resistance class
PE-HD, ABS, SAN+PVC			
Ø 110 mm	5,5 mm	1 x 4 layers 100 mm width	EI 90 U/U

KSL-W	Annex 10.1
Fire Stopping and Sealing with high performance intumescent material used in penetration seals	

Annex 11

Description of possible additional components of the penetration seal

Description of possible additional components of the penetration seal		
Description	Performance	Sample Product
Insulation made of flexible elastomeric foam (FEF) in accordance with EN 14304	Reaction to fire class acc. to EN 13501-1: B-s3, d0 resp. D-s1,do	Armalok 50 Armalok 100 ArmaFlex SE ArmaFlex XG AF/ArmaFlex AF/ArmaFlex Evo SH/ArmaFlex NH/ArmaFlex NH/ArmaFlex Smart HT/ArmaFlex ArmaFlex Ultima Kaiflex HT s2 Kaiflex KK Kaiflex KKplus s2 Kaiflex KKplus s3 FLEXEN Heizungskautschuk s2 FLEXEN Kältekautschuk Plus s2 isopren Plus isopren Polar Plus K-FLEX ST K-FLEX ST PLUS K-FLEX ECO K-FLEX H Eurobatex Eurobatex SC Eurobatex High Technology Eurobatex H Eurobatex H Super Eurobatex Glastec
Insulation made of polyethylene foam (PEF) in accordance with EN 14313	Reaction to fire class acc. to EN 13501-1: E	KeKelit Lexel Würth FLEXEN PE Würth FLEXEN Schallschutz Steinbacher Steinoflex 440 (Geberit)
Loose mineral wool in accordance with EN 14303	Reaction to fire class acc. to EN 13501-1: A1 Melting point: ≥ 1000 °C	Knauf Insulation LW; Rockwool "ProRox LF 970"
Mineral fibre board in accordance with DIN EN 13162	Reaction to fire class acc. to EN 13501-1: A1 Nominal Density: ≥ 150 kg/m ³ Melting point: ≥ 1000 °C	Rockwool "Hardrock 040" Paroc Pyrotech Slab 160 Rockwool "RP-GF 70"

KSL-W	Annex 11
Fire Stopping and Sealing with high performance intumescent material used in penetration seals	